

# Axor® Urquiola

3-Hole lavatory faucet / Robinet grande écartement / Batéria americana para lavabo

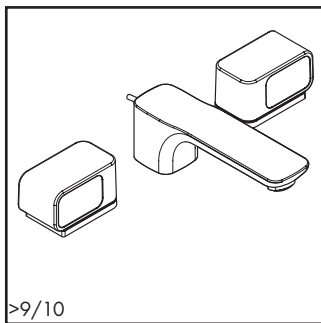

>9/10

11041xx1

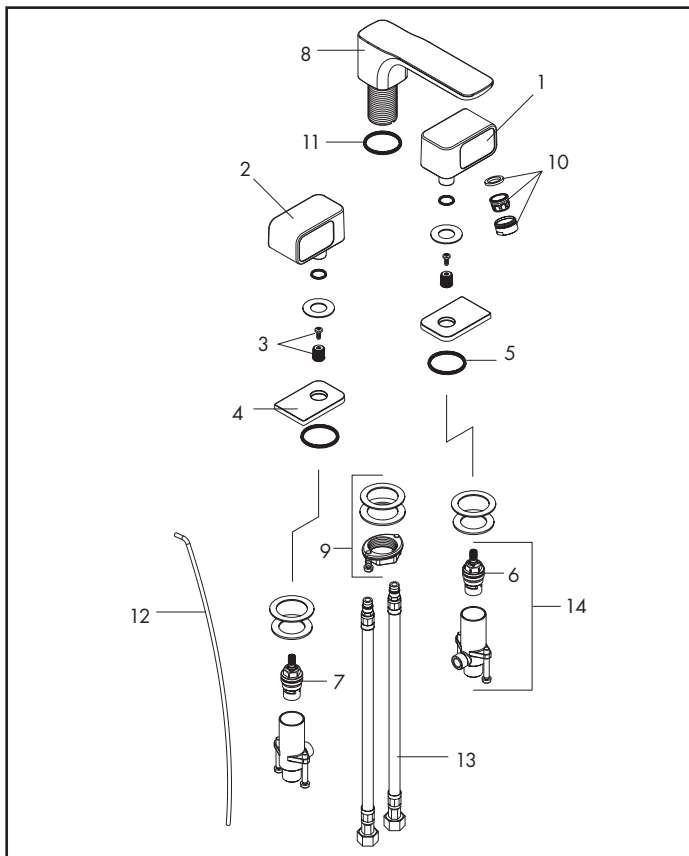

Pos.	Description	Description	Denominación	No./Nr./N°	PG
1	cold handle	poignée, froide	manija, fría	95305xx0	1 99
2	hot handle	poignée, chaude	manija, caliente	95304xx0	1 99
3	handle fixing set	entraîneur + vis	anclaje para manija	98932000	1 5
4	escutcheon	rosace pour poignée	florón para manija	95307xx0	1 99
5	34x4 o-ring	joint torique 34 x 4	junta toroidal 34 x 4	98155000	1 1
6	cold cartridge	mécanisme eau froide	montura agua fría	94008000	1 10
7	hot cartridge	mécanisme eau chaude	montura agua caliente	94009000	1 10
8	spout	bec	caño	95303xx0	1 99
9	fixing set	fixation	set de fijación	13961000	1 7
10	aerator	aérateur	aireador	13185xx0	1 8*
11	sealing ring	joint	junta	98749000	1 99
12	pull rod	tirette	tirador	96676xx0	1 7*
13	connection hose 18"	flexible de raccordement 18"	conexión flexible 18"	96321001	1 8
14	valve	robinet d'arrêt	válvula completa	97357001	1 15
	pop-up drain, see p. 4.171	vidage lavabo voir p. 4.171	vaciadores ver p. 4.171	94159xx0	1 14*

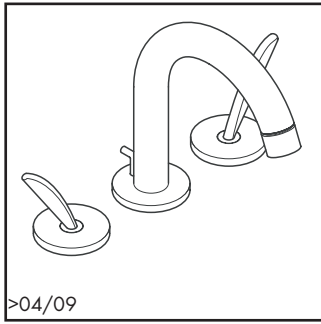

>04/09

10133xx1

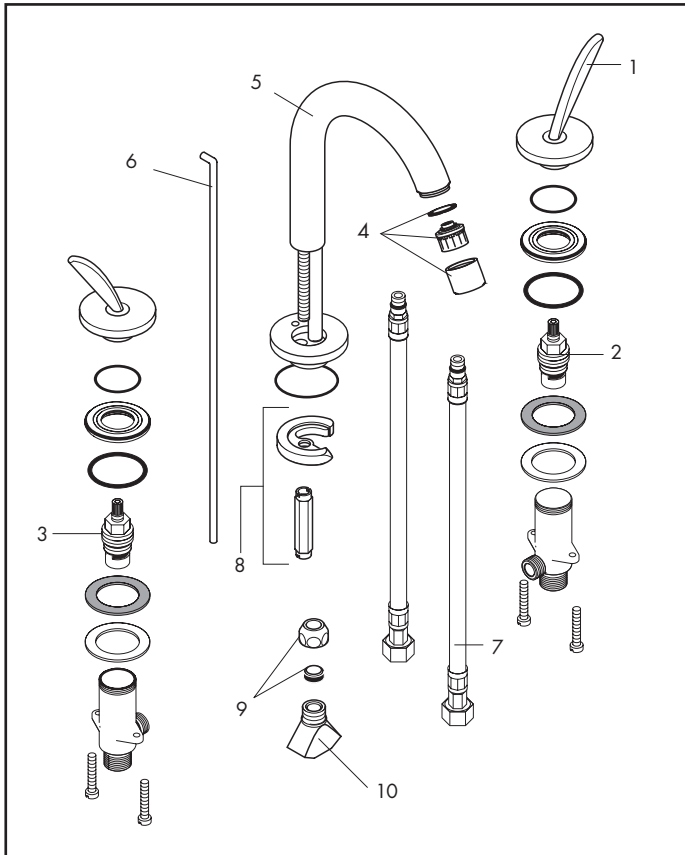

Pos.	Description	Description	Denominación	No./Nr./N°	PG
1	handle	poignée	manija	10091xx0	1 16*
2	cold cartridge	mécanisme eau froide	montura agua fría	94008000	1 10
3	hot cartridge	mécanisme eau chaude	montura agua caliente	94009000	1 10
4	aerator	aérateur	aireador	95455xx0	1 99
5	spout	bec	caño	94014xx0	1 18*
6	pull rod	tirette	tirador	94083xx0	1 9*
7	connection hose	flexible de raccordements	conexión flexible 13"	94071001	1 9
8	fixing set	fixation	set de fijación	94701000	1 10
9	compression fitting	raccord à bague sertie	tuercas grifería	94158000	set 3
10	hose connection angle	coude de raccordement flexible	rácor conexión flexo	97753000	1 10
	pop-up drain, see p. 4.171	vidage lavabo voir p. 4.171	vaciadores ver p. 4.171	94159xx0	1 14*

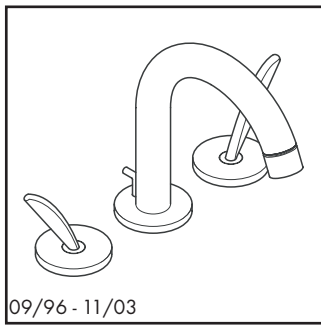

10133xx1

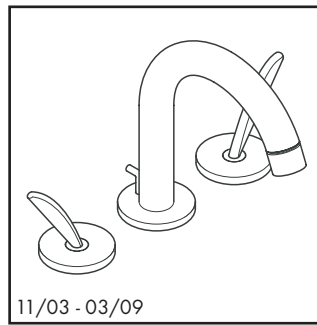

10133xx1

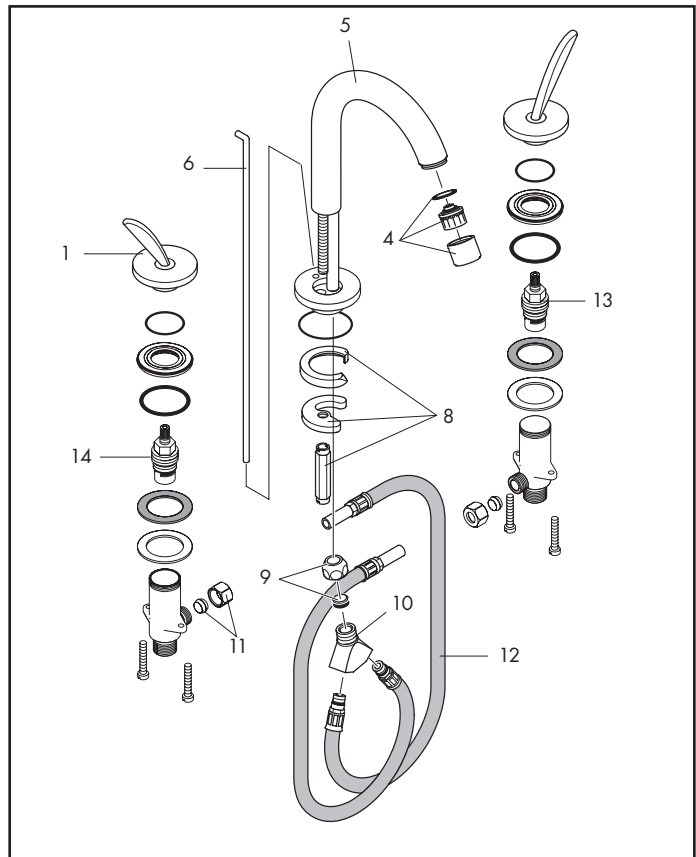
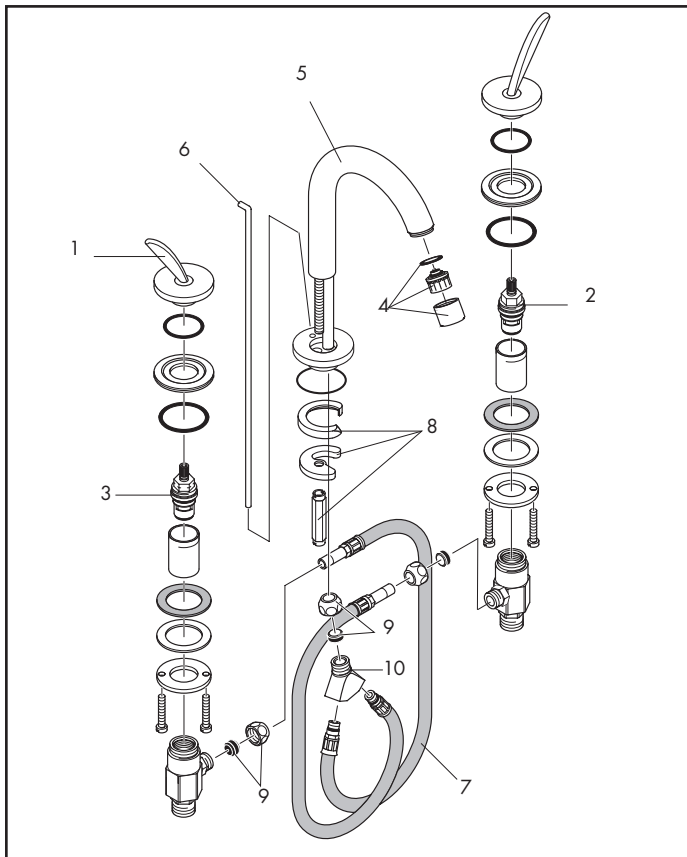

Pos.	Description	Description	Denominación	No./Nr./N°	PG
1	handle	poignée	manija	10091xx0	1 16*
2	cold cartridge	mécanisme eau froide	montura agua fría	96765000	1 11
3	hot cartridge	mécanisme eau chaude	montura agua caliente	96766000	1 11
4	aerator	aérateur	aireador	94010xx0	1 10*
5	spout	bec	caño	94014xx0	1 18*
6	pull rod	tirette	tirador	94083xx0	1 9*
7	connection hose	flexible de raccordements	conexión flexible 13"	94071000	1 8
8	fixing set	fixation	set de fijación	94701000	1 10
9	compression fitting	raccord à bague sertie	tuercas grifería	94158000	set 3
10	hose connection angle	coude de raccordement flexible	rácór conexión flexo	97753000	1 10
11	3/8 compression fittings (pair)	raccord à bague sertie 3/8 (2 pièces)	tuercas grifería 3/8 (2 pieza)	88513000	set 4
12	connection hose	flexible de raccordements	conexión flexible 13"	94071001	1 9
13	cold cartridge	mécanisme eau froide	montura agua fría	94008000	1 10
14	hot cartridge	mécanisme eau chaude	montura agua caliente	94009000	1 10
	pop-up drain, see p. 4.171	vidage lavabo voir p. 4.171	vaciadores ver p. 4.171	94159xx0	1 14*

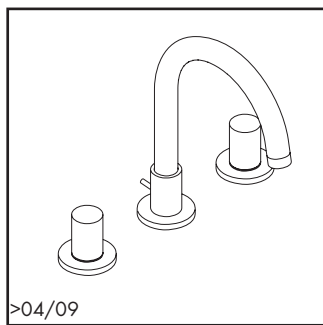

>04/09

10135xx1

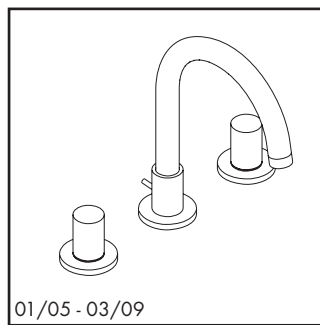

01/05 - 03/09

10135xx1

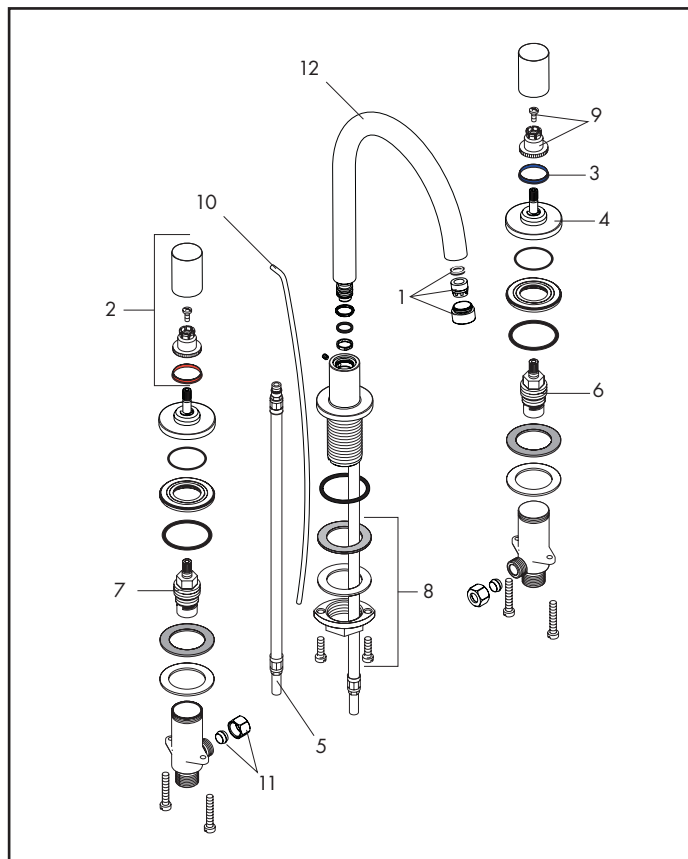
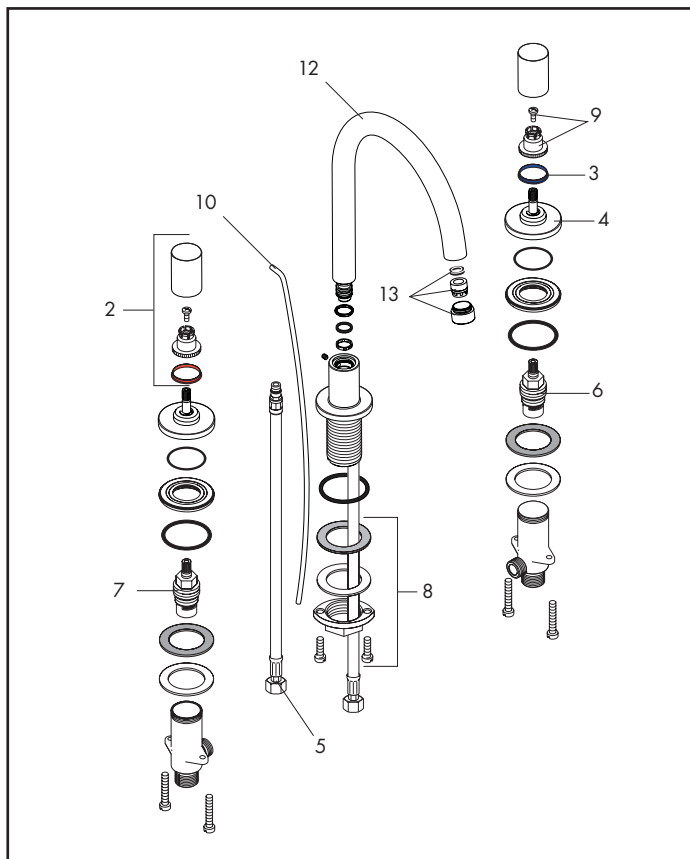

Pos.	Description	Description	Denominación	No./Nr./N°	PG
1	aerator	aérateur	aireador	96911xx0	1 9*
2	handle	poignée	manija	96318xx0	1 14*
3	hot/cold color rings	bague couleur eau chaude/froide	anillo frío/caliente	96319000	set 4
4	escutcheon	rosace pour poignée	florón para manija	97285xx0	1 11*
5	connection hose 18"	flexible de raccordements 18"	conexión flexible 18"	94071001	1 9
6	cold cartridge	mécanisme eau froide	montura agua fría	94008000	1 10
7	hot cartridge	mécanisme eau chaude	montura agua caliente	94009000	1 10
8	fixing set	fixation	set de fijación	13961000	1 7
9	handle fixing set	entraîneur + vis	anclaje para manija	94184000	1 2
10	pull rod	tirette	tirador	96657000	1 4*
11	3/8" compression fittings (pair)	raccord à bague sertie 3/8" (2 pièces)	tuercas grifería 3/8" (2 pieza)	88513000	set 4
12	spout	bec	caño	97363xx0	1 16*
13	aerator	aérateur	aireador	95387xx0	1 99
	pop-up drain, see p. 4.171	vidage lavabo voir p. 4.171	vaciadores ver p. 4.171	94159xx0	1 14*

# Axor® Citterio

3-Hole lavatory faucet / Robinet grande écartement / Batéria americana para lavabo

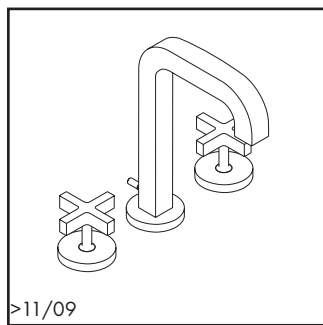

>11/09

39133xx1

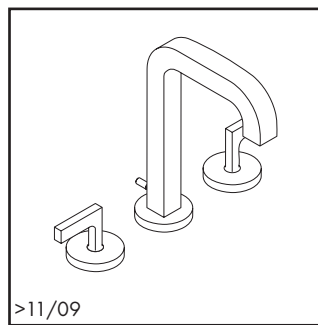

>11/09

39135xx1

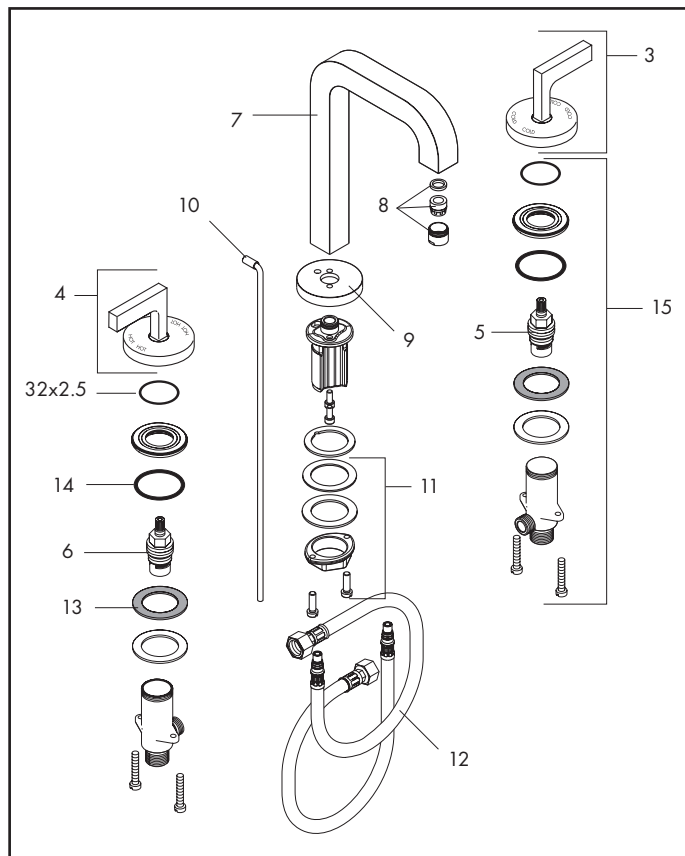
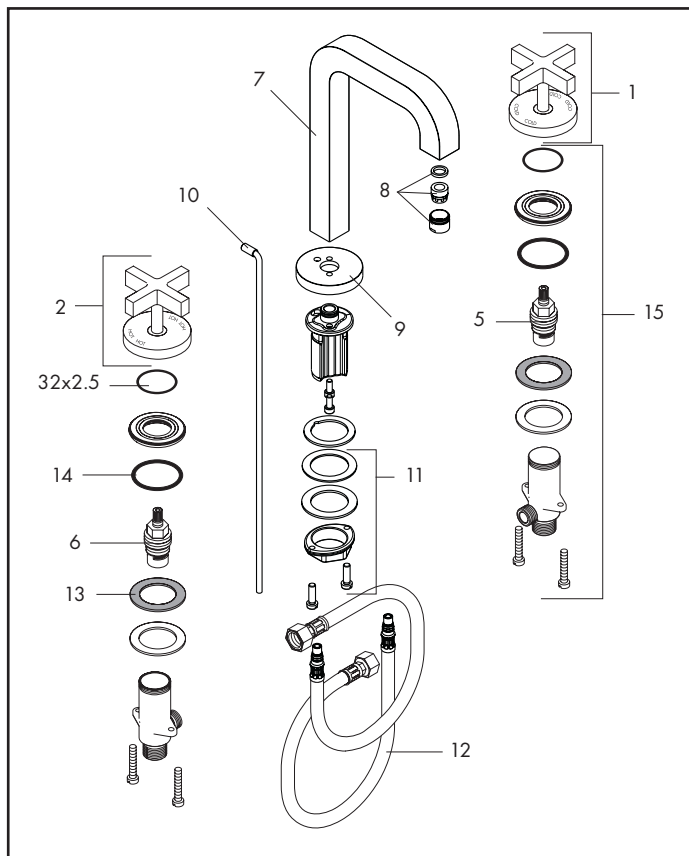

Pos.	Description	Description	Denominación	No./Nr./N°	PG
1	cross handle, cold	poignée croisillon, froide	manija en cruz, fría	39297xx0	1 14*
2	cross handle, hot	poignée croisillon, chaude	manija en cruz, caliente	39298xx0	1 13*
3	lever handle, cold	poignée levier, froide	manija tipo palanca, fría	39093xx0	1 15*
4	lever handle, hot	poignée levier, chaude	manija tipo palanca, caliente	39094xx0	1 15*
5	cold cartridge	mécanisme eau froide	montura agua fría	94008000	1 10
6	hot cartridge	mécanisme eau chaude	montura agua caliente	94009000	1 10
7	spout 6 1/2"	bec 6 1/2"	caño 6 1/2"	96674xx0	1 21*
8	aerator M18x1	aérateur M18x1	aireador M18x1	95384xx0	1 99
9	spout escutcheon	rosace pour bec	florón para caño	97804xx0	1 99
10	pull rod	tirette	tirador	96676xx0	1 7*
11	fixing set	fixation	set de fijación	13961000	1 7
12	connection hose 18"	flexible de raccordement 18"	conexión flexible 18"	96321001	1 8
13	lever collar	anneau plastique	arandela	97548000	1 1
14	O-ring 40x3	Joint torique 40x3	junta toroidal 40x3	92634000	1 99
15	stop valve	robinet d'arrêt	válvula completa	97357001	1 15
	pop-up drain, see p. 4.171	vidage lavabo voir p. 4.171	vaciadores ver p. 4.171	94159xx0	1 14*

4.100  
6/2011

xx = Please see p. 4.1 for finish codes / \*PG is for Chrome only. See the index for other finishes.  
xx = Description des codes couleur page 4.1 / \*PG concerne Chromé seulement. Pour les autres, voir dans la liste des références.  
xx = Para el código de acabados ver p. 4.1 / \*La PG vale para Cromado solo. Ver el índice para las otras superficies.

**hansgrohe**

# Axor® Citterio

3-Hole lavatory faucet / Robinet grande ecartement / Batéria americana para lavabo

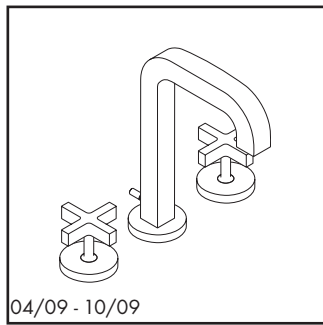

39133xx1

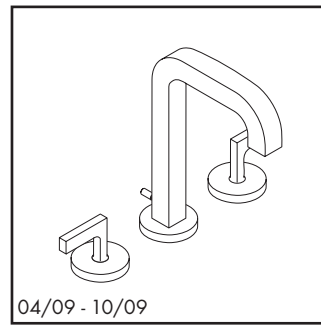

39135xx1

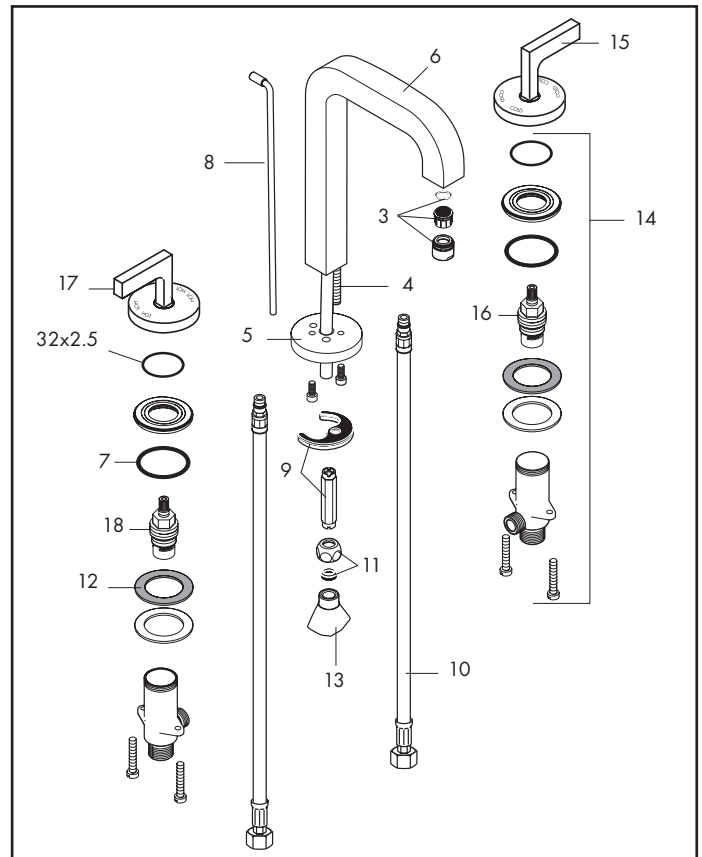
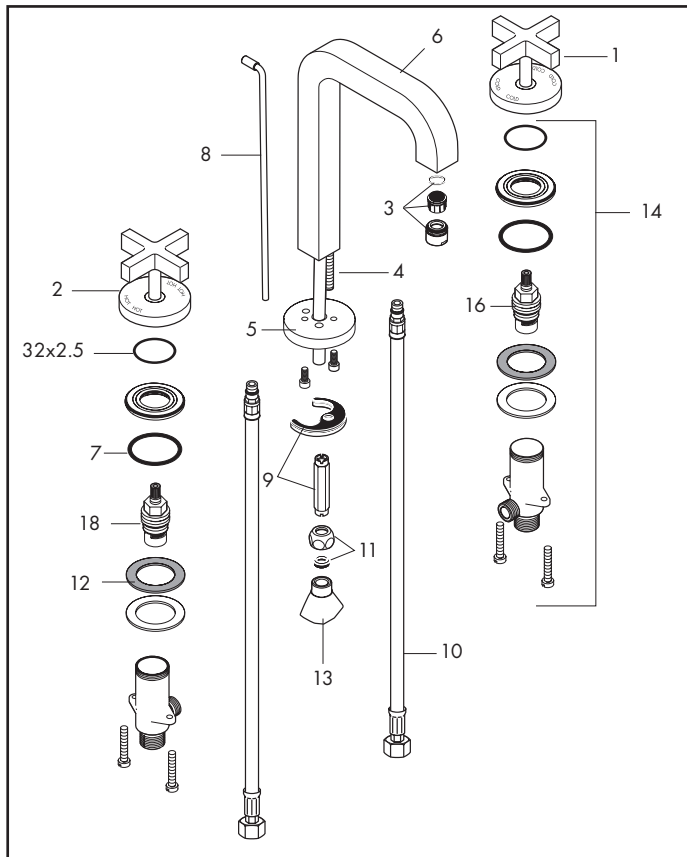

Pos.	Description	Description	Denominación	No./Nr./N°	PG
1	cross handle, cold	poignée croisillon, froide	manija en cruz, fría	39297xx0	1 14*
2	cross handle, hot	poignée croisillon, chaude	manija en cruz, caliente	39298xx0	1 13*
3	aerator M18x1	aérateur M18x1	airedador M18x1	88743xx0	1 9*
4	screw M8x68	vis M8x68	tornillo M8x68	97736000	1 3
5	spout escutcheon	rosace pour bec	florón para caño	97804xx0	1 99
6	spout 6 1/2"	bec 6 1/2"	caño 6 1/2"	96674xx0	1 21*
7	O-ring 40x3	Joint torique 40x3	junta toroidal 40x3	92634000	1 99
8	pull rod	tirette	tirador	96676xx0	1 7*
9	fixing set	fixation	set de fijación	96016000	1 9
10	connection hose 18"	flexible de raccordement 18"	conexión flexible 18"	94071000	1 8
11	compression fitting	raccord à bague sertie	tuercas grifería	94158000	set 3
12	lever collar	anneau plastique	arandela	97548000	1 1
13	hose connection angle	coude de raccordement flexible	rácor conexión flexo	97753000	1 10
14	stop valve	robinet d'arrêt	válvula completa	97357001	1 15
15	lever handle, cold	poignée levier, froide	manija tipo palanca, fría	39093xx0	1 15*
16	cold cartridge	mécanisme eau froide	montura agua fría	94008000	1 10
17	lever handle, hot	poignée levier, chaude	manija tipo palanca, caliente	39094xx0	1 15*
18	hot cartridge	mécanisme eau chaude	montura agua caliente	94009000	1 10
	pop-up drain, see p. 4.171	vidage lavabo voir p. 4.171	vaciadores ver p. 4.171	94159xx0	1 14*

# Axor® Citterio

3-Hole lavatory faucet / Robinet grande écartement / Batéria americana para lavabo

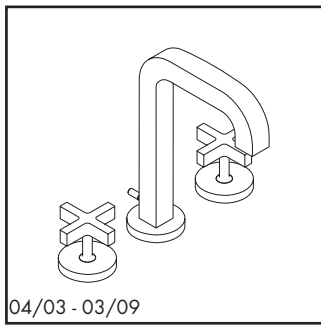

39133xx1

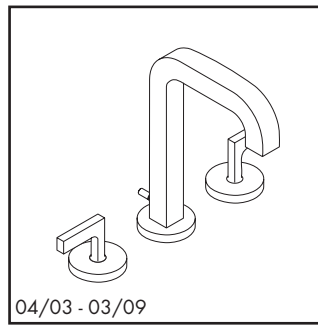

39135xx1

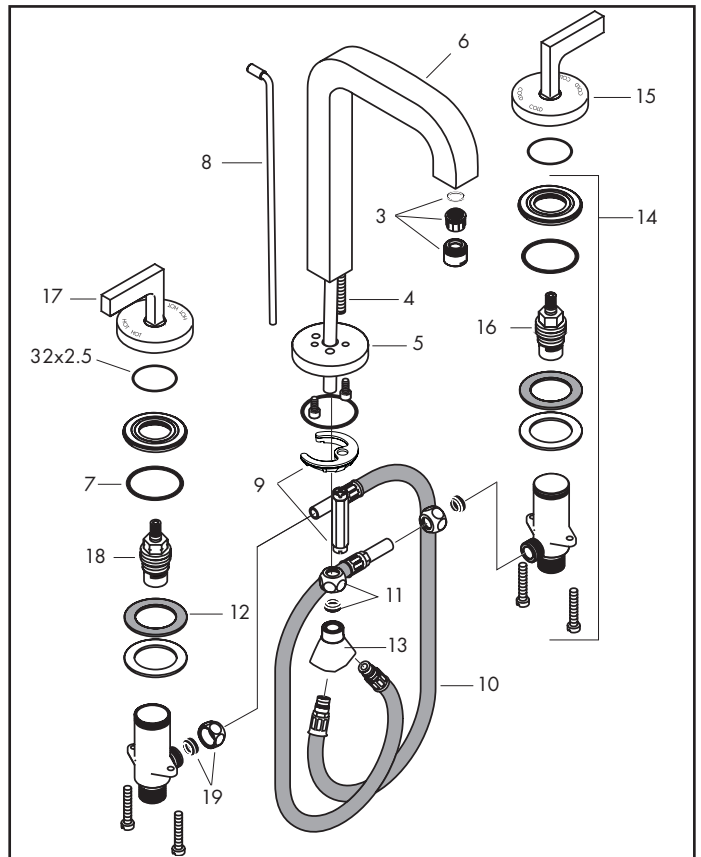
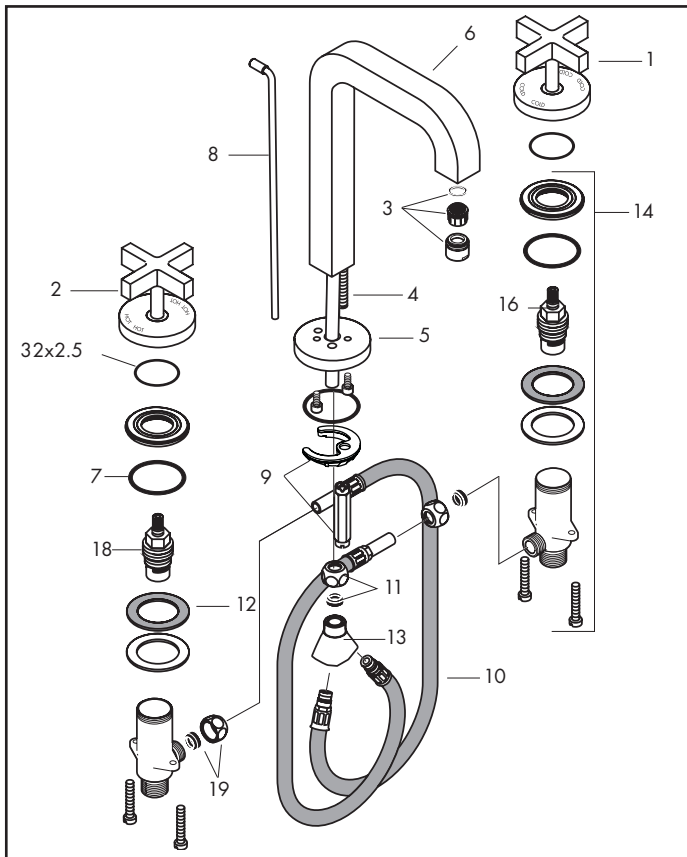

Pos.	Description	Description	Denominación	No./Nr./N°	PG
1	cross handle, cold	poignée croisillon, froide	manija en cruz, fría	39297xx0	1 14*
2	cross handle, hot	poignée croisillon, chaude	manija en cruz, caliente	39298xx0	1 13*
3	aerator M18x1	aérateur M18x1	aireador M18x1	96673000	1 10
4	screw M8x68	vis M8x68	tornillo M8x68	97736000	1 3
5	spout escutcheon	rosace pour bec	florón para caño	97804xx0	1 99
6	spout 6 1/2"	bec 6 1/2"	caño 6 1/2"	96674xx0	1 21*
7	O-ring 40x3	Joint torique 40x3	junta toroidal 40x3	92634000	1 99
8	pull rod	tirette	firador	96676xx0	1 7*
9	fixing set	fixation	set de fijación	96016000	1 9
10	connection hose 18"	flexible de raccordement 18"	conexión flexible 18"	94071001	1 9
11	compression fitting	raccord à bague sertie	tuercas grifería	94158000	set 3
12	lever collar	anneau plastique	arandela	97548000	1 1
13	hose connection angle	coude de raccordement flexible	rácor conexión flexo	97753000	1 10
14	stop valve	robinet d'arrêt	válvula completa	97357001	1 15
15	lever handle, cold	poignée levier, froide	manija tipo palanca, fría	39093xx0	1 15*
16	cold cartridge	mécanisme eau froide	montura agua fría	94008000	1 10
17	lever handle, hot	poignée levier, chaude	manija tipo palanca, caliente	39094xx0	1 15*
18	hot cartridge	mécanisme eau chaude	montura agua caliente	94009000	1 10
19	3/8" compression fitting	raccord à bague sertie 3/8"	tuercas grifería 3/8"	88513000	set 4
	pop-up drain, see p. 4.171	vidage lavabo voir p. 4.171	vaciadores ver p. 4.171	94159xx0	1 14*

# Axor® Citterio

3-Hole lavatory faucet / Robinet grande ecartement / Batéria americana para lavabo

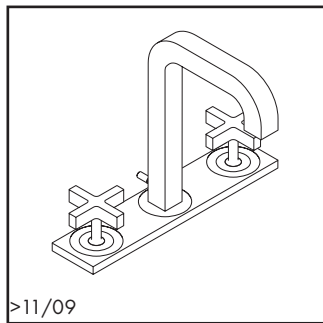

39134xx1

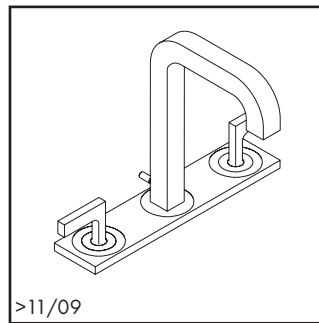

39136xx1

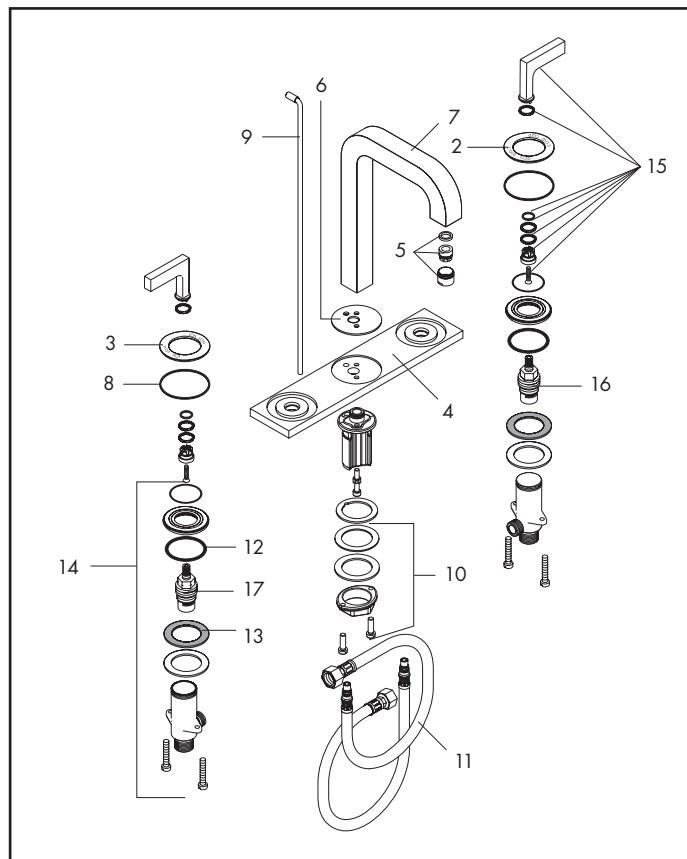
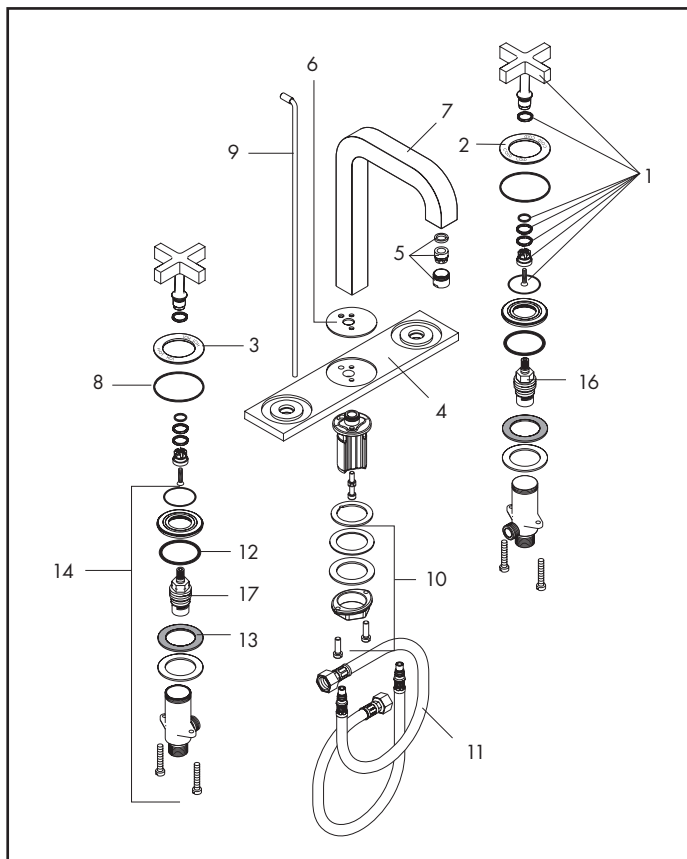

Pos.	Description	Description	Denominación	No./Nr./N°	PG
1	cross handle	poignée croisillon	manija en cruz	39291xx0	1 11*
2	cold escutcheon	rosace eau froide	embellecedor agua fría	96679xx0	1 99
3	hot escutcheon	rosace eau chaude	embellecedor agua caliente	96678xx0	1 99
4	escutcheon	rosace	florón	96680xx0	1 17*
5	aerator M18x1	aérateur M18x1	aireador M18x1	95384xx0	1 99
6	spout escutcheon	rosace pour bec	florón para caño	97803xx0	1 13*
7	spout 6 1/2"	bec 6 1/2"	caño 6 1/2"	96674xx0	1 21*
8	O-ring 52x4.5	joint torique 52x4.5	junta toroidal 52x4.5	98200000	1 99
9	pull rod	tirette	tirador	96676xx0	1 7*
10	fixing set	fixation	set de fijación	13961000	1 7
11	connection hose 18"	flexible de raccordement 18"	conexión flexible 18"	96321001	1 8
12	O-ring 40x3	joint torique 40x3	junta toroidal 40x3	92634000	1 99
13	lever collar	anneau plastique	arandela	97548000	1 1
14	stop valve	robinet d'arrêt	válvula completa	97357001	1 15
15	lever handle	poignée levier	manija tipo palanca	39293xx0	1 12*
16	cold cartridge	mécanisme eau froide	montura agua fría	94008000	1 10
17	hot cartridge	mécanisme eau chaude	montura agua caliente	94009000	1 10
	pop-up drain, see p. 4.171	vidage lavabo voir p. 4.171	vaciadores ver p. 4.171	94159xx0	1 14*



xx = Please see p. 4.1 for finish codes / \*PG is for Chrome only. See the index for other finishes.  
 xx = Description des codes couleur page 4.1 / \*PG concerne Chromé seulement. Pour les autres, voir dans la liste des références.  
 xx = Para el código de acabados ver p. 4.1 / \*La PG vale para Cromado solo. Ver el índice para las otras superficies.



# Axor® Citterio

3-Hole lavatory faucet / Robinet grande écartement / Batéria americana para lavabo

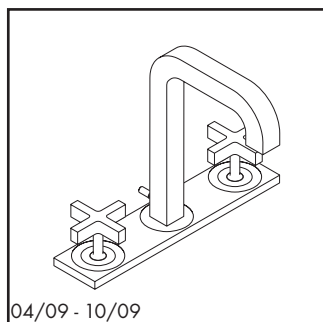

04/09 - 10/09

39134xx1

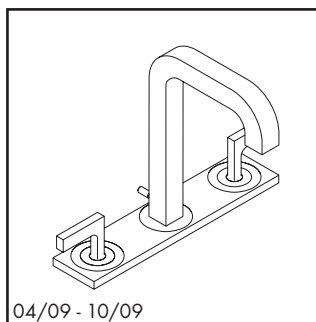

04/09 - 10/09

39136xx1

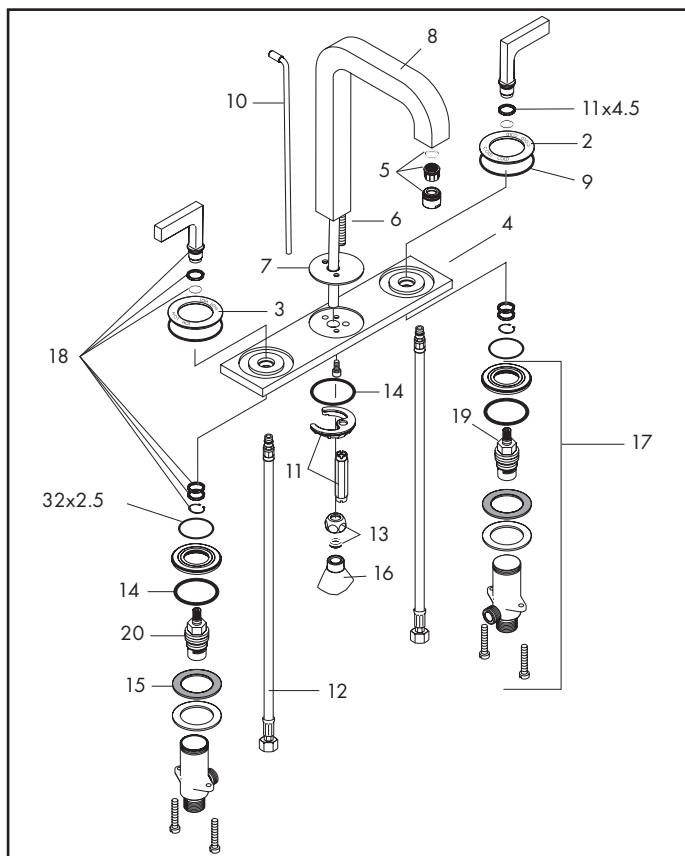
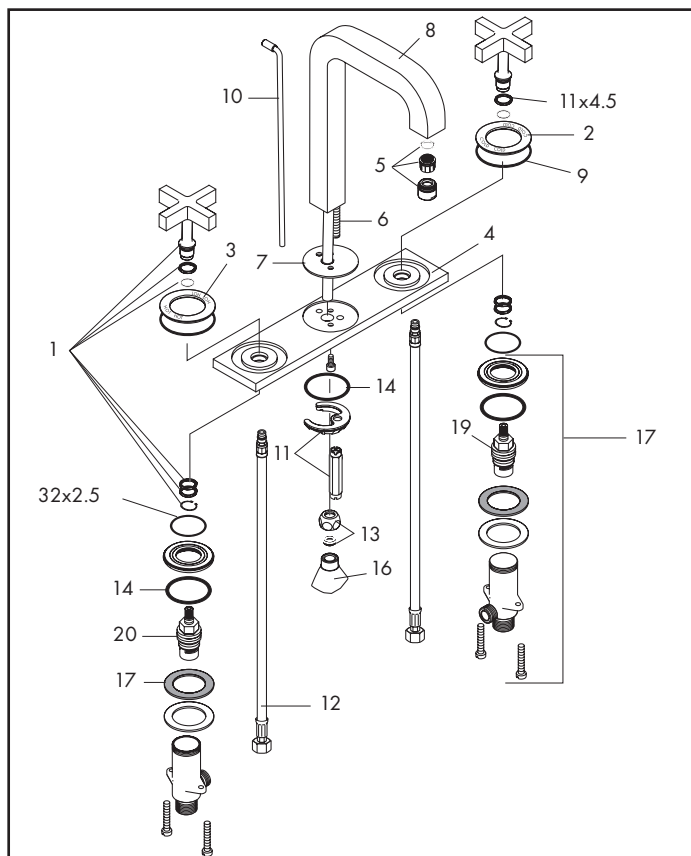

Pos.	Description	Description	Denominación	No./Nr./N°	PG
1	cross handle	poignée croisillon	manija en cruz	39291xx0	1 11*
2	cold escutcheon	rosace eau froide	embellecedor agua fría	96679xx0	1 99
3	hot escutcheon	rosace eau chaude	embellecedor agua caliente	96678xx0	1 99
4	escutcheon	rosace	florón	96680xx0	1 17*
5	aerator M18x1	aérateur M18x1	aireador M18x1	88743xx0	1 9*
6	screw M8x68	vis M8x68	tornillo M8x68	97736000	1 3
7	spout escutcheon	rosace pour bec	florón para caño	97803xx0	1 11*
8	spout 6 1/2"	bec 6 1/2"	caño 6 1/2"	96674xx0	1 21*
9	O-ring 52x4.5	Joint torique 52x4.5	junta toroidal 52x4.5	98200000	1 99
10	pull rod	tirette	tirador	96676xx0	1 7*
11	fixing set	fixation	set de fijación	96016000	1 9
12	connection hose 18"	flexible de raccordement 18"	conexión flexible 18"	94071001	1 8
13	compression fitting	raccord à bague sertie	tuerca grifería	94158000	set 3
14	O-ring 40x3	Joint torique 40x3	junta toroidal 40x3	92634000	1 99
15	lever collar	anneau plastique	arandela	97548000	1 1
16	hose connection angle	coude de raccordement flexible	rácór conexión flexo	97753000	1 10
17	stop valve	robinet d'arrêt	válvula completa	97357001	1 15
18	lever handle	poignée levier	manija tipo palanca	39293xx0	1 12*
19	cold cartridge	mécanisme eau froide	montura agua fría	94008000	1 10
20	hot cartridge	mécanisme eau chaude	montura agua caliente	94009000	1 10
	pop-up drain, see p. 4.171	vidage lavabo voir p. 4.171	vaciadores ver p. 4.171	94159xx0	1 14*

# Axor® Citterio

3-Hole lavatory faucet / Robinet grande ecartement / Batéria americana para lavabo

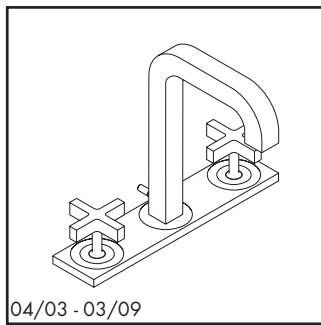

39134xx1

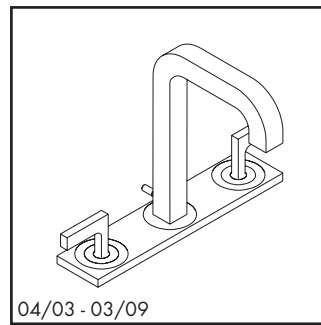

39136xx1

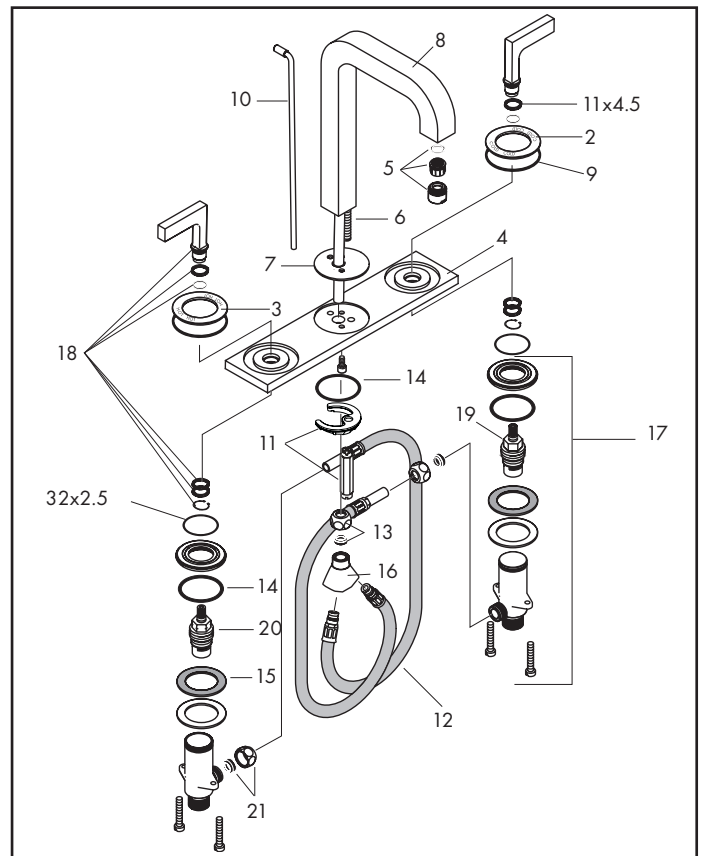
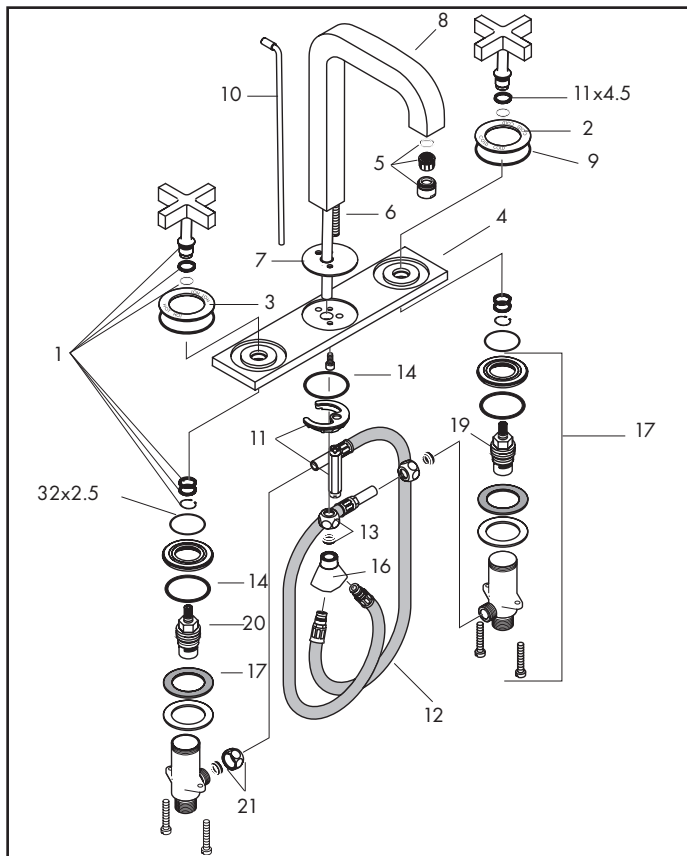

Pos.	Description	Description	Denominación	No./Nr./N°	PG
1	cross handle	poignée croisillon	manija en cruz	39291xx0	1 11*
2	cold escutcheon	rosace eau froide	embellecedor agua fría	96679xx0	1 99
3	hot escutcheon	rosace eau chaude	embellecedor agua caliente	96678xx0	1 99
4	escutcheon	rosace	florón	96680xx0	1 17*
5	aerator M18x1	aérateur M18x1	aireador M18x1	96673000	1 10
6	screw M8x68	vis M8x68	tornillo M8x68	97736000	1 3
7	spout escutcheon	rosace pour bec	florón para caño	97803xx0	1 11*
8	spout 6 1/2"	bec 6 1/2"	caño 6 1/2"	96674xx0	1 21*
9	O-ring 52x4.5	Joint torique 52x4.5	junta toroidal 52x4.5	98200000	1 99
10	pull rod	tirette	tirador	96676xx0	1 7*
11	fixing set	fixation	set de fijación	96016000	1 9
12	connection hose 18"	flexible de raccordement 18"	conexión flexible 18"	94071001	1 8
13	compression fitting	raccord à bague sertie	tueras grifería	94158000	set 3
14	O-ring 40x3	Joint torique 40x3	junta toroidal 40x3	92634000	1 99
15	lever collar	anneau plastique	arandela	97548000	1 1
16	hose connection angle	coude de raccordement flexible	rácor conexión flexo	97753000	1 10
17	stop valve	robinet d'arrêt	válvula completa	97357001	1 15
18	lever handle	poignée levier	manija tipo palanca	39293xx0	1 12*
19	cold cartridge	mécanisme eau froide	montura agua fría	94008000	1 10
20	hot cartridge	mécanisme eau chaude	montura agua caliente	94009000	1 10
21	3/8" compression fitting	raccord à bague sertie 3/8"	tueras grifería 3/8"	88513000	set 4
	pop-up drain, see p. 4.171	vidage lavabo voir p. 4.171	vaciadores ver p. 4.171	94159xx0	1 14*

# Axor® Citterio M

3-Hole lavatory faucet / Robinet grande écartement / Batéria americana para lavabo

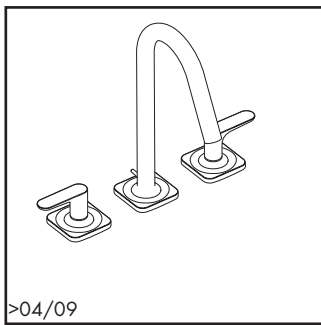

>04/09

34133xx1

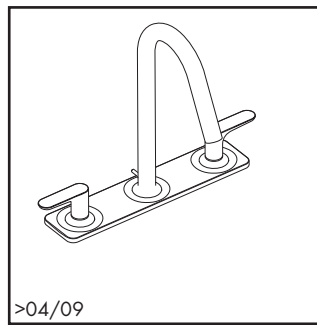

>04/09

34134xx1

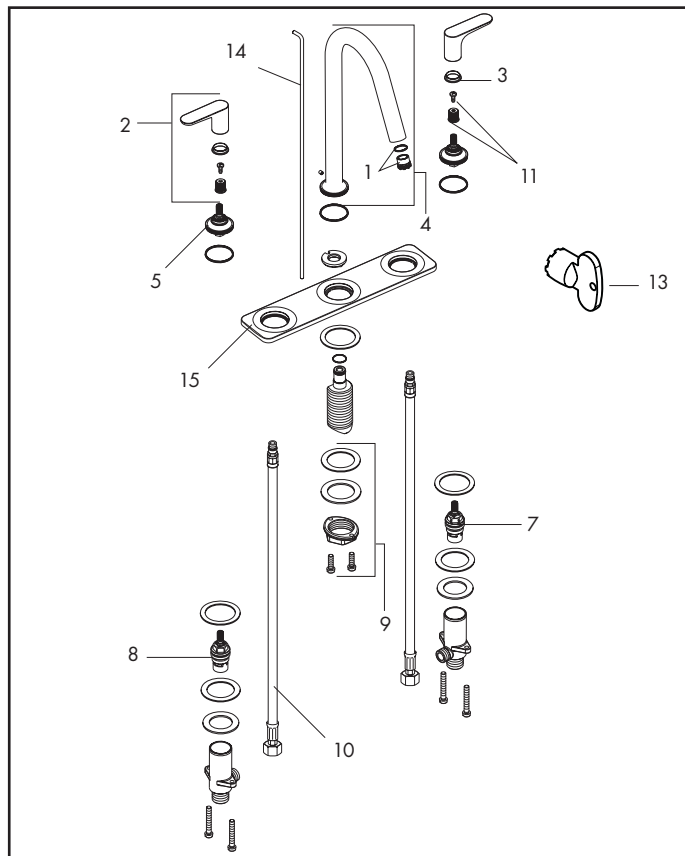
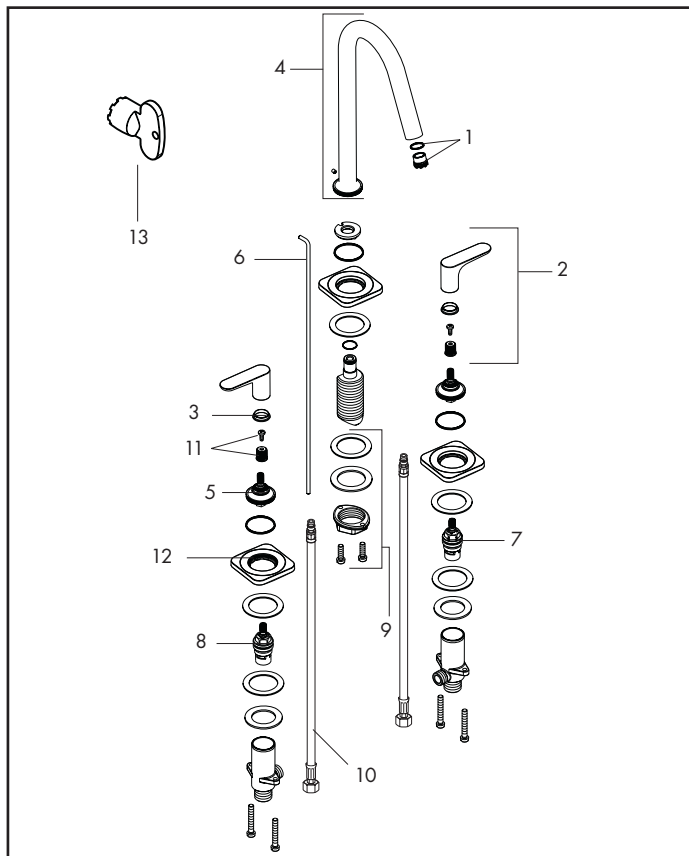

Pos.	Description	Description	Denominación	No./Nr./N°	PG
1	aerator	aérateur	aireador	95382xx0	1 99
2	handle	poignée	manija	34095xx0	1 12*
3	color-ring set	bague couleur eau chaude/froide	anillo agua frío/caliente	98927000	set 6
4	spout	bec	caño	98928xx0	1 20
5	nut	écrou	tuerca	98929xx0	1 12*
6	pull rod	tirette	tirador	96657xx0	1 7
7	cold cartridge	mécanisme eau froid	montura agua fría	94008000	1 10
8	hot cartridge	mécanisme eau chaude	montura agua caliente	94009000	1 10
9	fixing set	set de fixation	fijación complete	13961000	1 7
10	connection hose	flexible de raccordement	conexión flexible	94071001	1 9
11	handle fixing set	fixation pour manette	fijación para manija	98932000	1 5
12	flange	rosace	florón	98930000	1 10*
13	aerator service key	de montage	llave de montaje	98987000	1 3
14	pull rod	tirette	tirador	94083xx0	1 9*
15	baseplate	rosace	florón	98936xx0	1 99
	pop-up drain, see p. 4.171	vidage lavabo voir p. 4.171	vaciadores ver p. 4.171	94159xx0	1 14*

# Axor® Citterio M

3-Hole lavatory faucet / Robinet grande ecartement / Batéria americana para lavabo

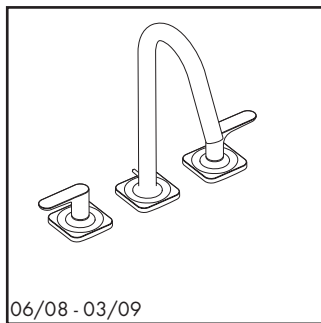

06/08 - 03/09

34133xx1

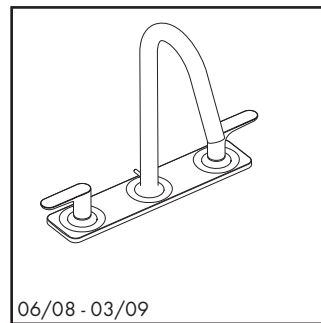
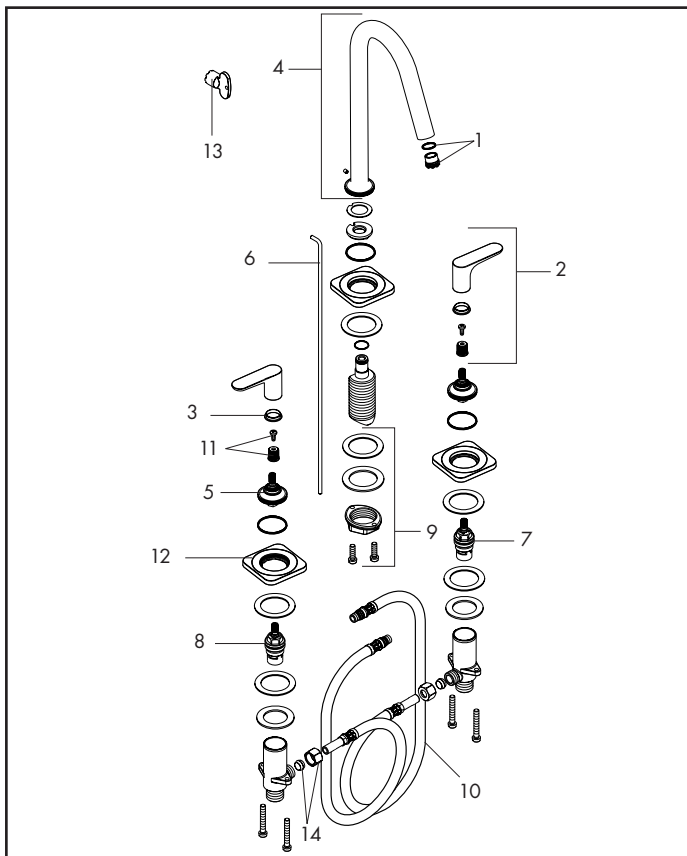

06/08 - 03/09

34134xx1

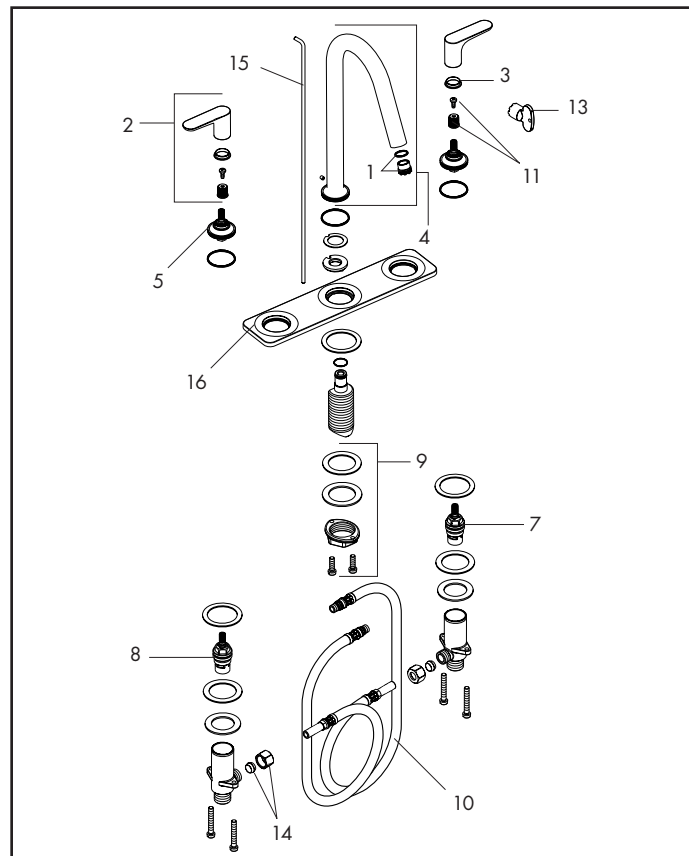

Pos.	Description	Description	Denominación	No./Nr./N°	PG
1	aerator	aérateur	aireador	98926000	1 11
2	handle	poignée	manija	34095xx0	1 12*
3	color-ring set	bague couleur eau chaude/froide	anillo agua frio/caliente	98927000	set 6
4	spout	bec	caño	98928xx0	1 20
5	nut	écrou	tuerca	98929xx0	1 12*
6	pull rod	tirette	tirador	96657xx0	1 7
7	cold cartridge	mécanisme eau froid	montura agua fría	94008000	1 10
8	hot cartridge	mécanisme eau chaude	montura agua caliente	94009000	1 10
9	fixing set	set de fixation	fijación complete	13961000	1 7
10	connection hose	flexible de raccordement	conexión flexible	94071001	1 9
11	handle fixing set	fixation pour manette	fijación para manija	98932000	1 5
12	flange	rosace	florón	98930000	1 10*
13	aerator service key	de montage	llave de montaje	98987000	1 3
14	compression ftgs. (pair)	raccord à bague sertie (2 pièce)	tuercas grifería (2 pieza)	88513000	set 4
15	pull rod	tirette	tirador	94083xx0	1 9*
16	baseplate	rosace	florón	98936xx0	1 99
	pop-up drain, see p. 4.171	vidage lavabo voir p. 4.171	vaciadores ver p. 4.171	94159xx0	1 14*

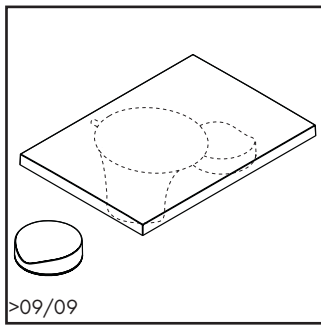

>09/09

18013001

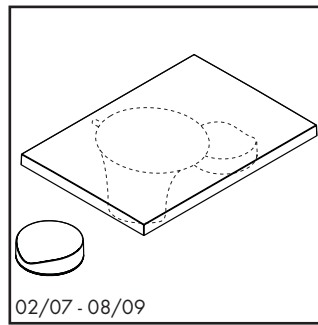

02/07 - 08/09

18013001

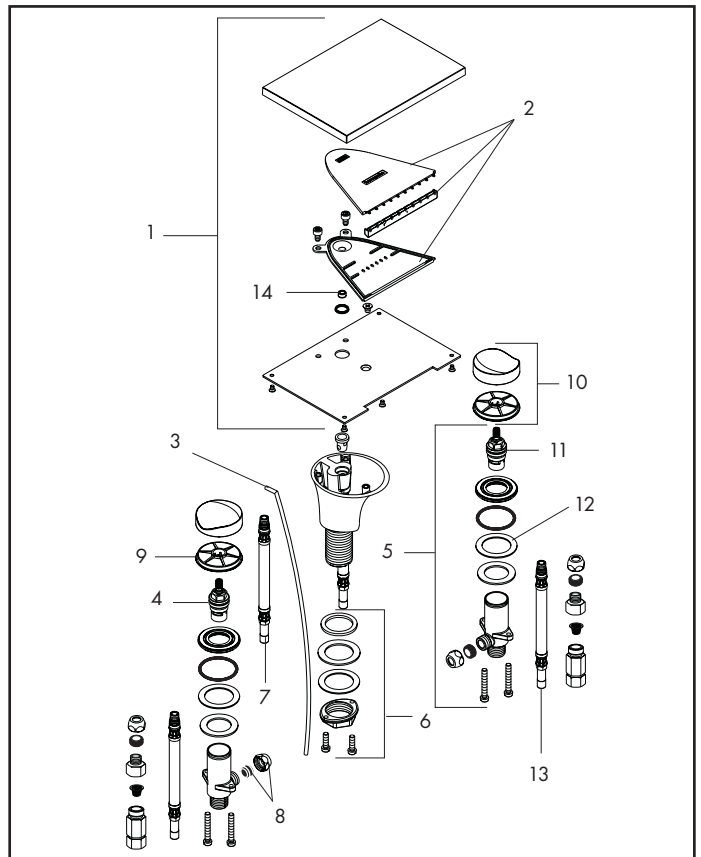
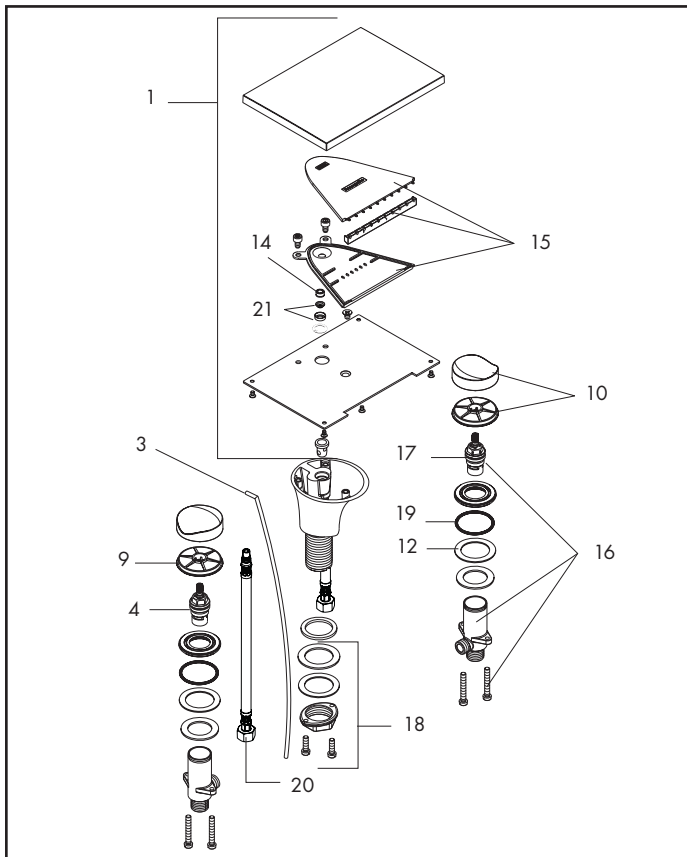

Pos.	Description	Description	Denominación	No./Nr./N°	PG
1	spout	bec	caño	98658000	1 20
2	spray former	diffuseur	moldeador de chorro	97447000	1 12
3	pull rod	tirette	tirador	97158000	1 8*
4	hot cartridge	mécanisme eau chaude	montura agua caliente	94009000	1 10
5	valve	robinet d'arrêt	válvula completa		1 99
6	fixing set	fixation	set de fijación	13961000	1 7
7	connection hose	flexible de raccordement	conexión flexible	94071000	1 8
8	compression fitting	raccord à bague sertie	tuercas grifería	94158000	set 3
9	color ring, red/blue	anneau rouge/bleu	anillo rojo/azul	98660000	1 7
10	handle	poignée	manija	18094000	1 12
11	cold cartridge	mécanisme eau froide	montura agua fría	94008000	1 10
12	lever collar	anneau plastique	anillo plástico	97548000	1 1
13	connection hose	flexible de raccordement	conexión flexible	13099000	1 9
14	flow limiter	limiteur de débit	waterdimmer	13968000	set 99
15	spray former	diffuseur	moldeador de chorro	97446000	1 99
16	valve	robinet d'arrêt	válvula completa	97357001	1 15
17	cold cartridge	mécanisme eau froide	montura agua fría	94008000	1 10
18	fixing set	fixation	set de fijación	97774000	set 99
19	seal	joint	joint	98749000	1 99
20	connection hose	flexible de raccordement	conexión flexible	94071001	1 9
21	filter	filtre	filtro	98516000	set 99
	pop-up drain, see p. 4.171	vidage lavabo voir p. 4.171	vaciadores ver p. 4.171	94159000	1 14*

# Axor® Steel

3-Hole lavatory faucet / Robinet grande ecartement / Batéria americana para lavabo

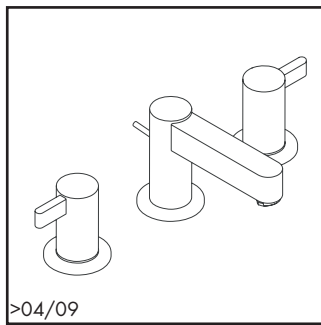

35033801

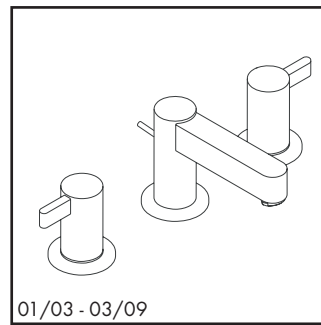

35033801

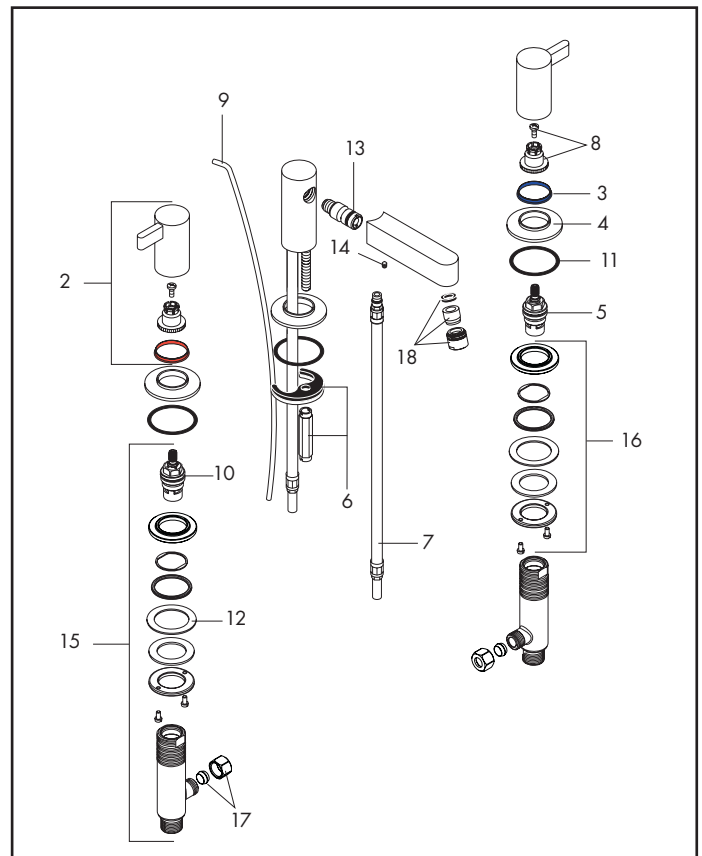
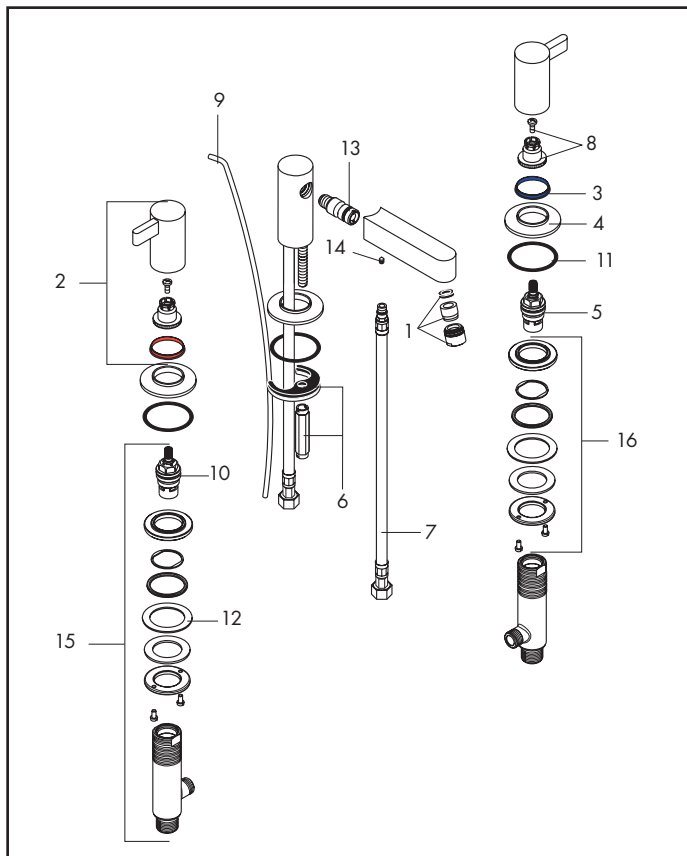

Pos.	Description	Description	Denominación	No./Nr./N°	PG
1	aerator	aérateur	aireador	95386800	1 99
2	handle	poignée	manija	35293800	1 15
3	color ring hot / cold	bague couleur eau chaude/froid	anillo frío / caliente	97127000	set 5
4	escutcheon	rosace	florón	97128800	1 9
5	cold cartridge	mecanisme eau froid	montura agua fría	94008000	1 10
6	fixing set	fixation	set de fijación	96016000	1 9
7	connection hose 18"	flexible de raccords 18"	conexión flexible 18"	94071001	1 9
8	handle fixing set	entraîneur + vis	anclaje para manija	94184000	1 2
9	pull rod	tirette	tirador	96657800	1 8
10	hot cartridge	mecanisme eau chaude	montura agua caliente	94009000	1 10
11	sealing ring	joint	junta	92634000	1 99
12	lever collar	mandrin	inserción	97548000	1 1
13	O-ring 11x2	joint torique 11x2	junta toroidal 11x2	98127000	set 1
14	screw M8x68	vis M8x68	tornillo M8x68	97736000	1 3
15	valve set	robinet d'arrêt	válvula completa	88503000	set 17
16	mounting kit	fixation	set de fijación	88511000	1 7
17	3/8 compression fittings (pair)	raccord à bague sertie 3/8 (2 pièces)	tuercas grifería 3/8 (2 pieza)	88513000	set 4
18	aerator	aérateur	aireador	96683800	1 8
	pop-up drain, see p. 4.171	vidage lavabo voir p. 4.171	vaciadores ver p. 4.171	94159xx0	1 14*

# Axor® Uno

3-Hole lavatory faucet / Robinet grande écartement / Batéria americana para lavabo

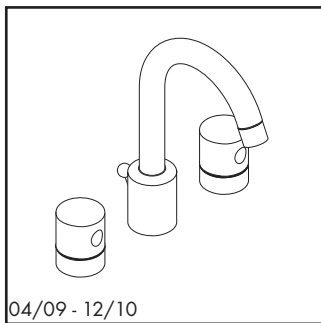

38033xx1

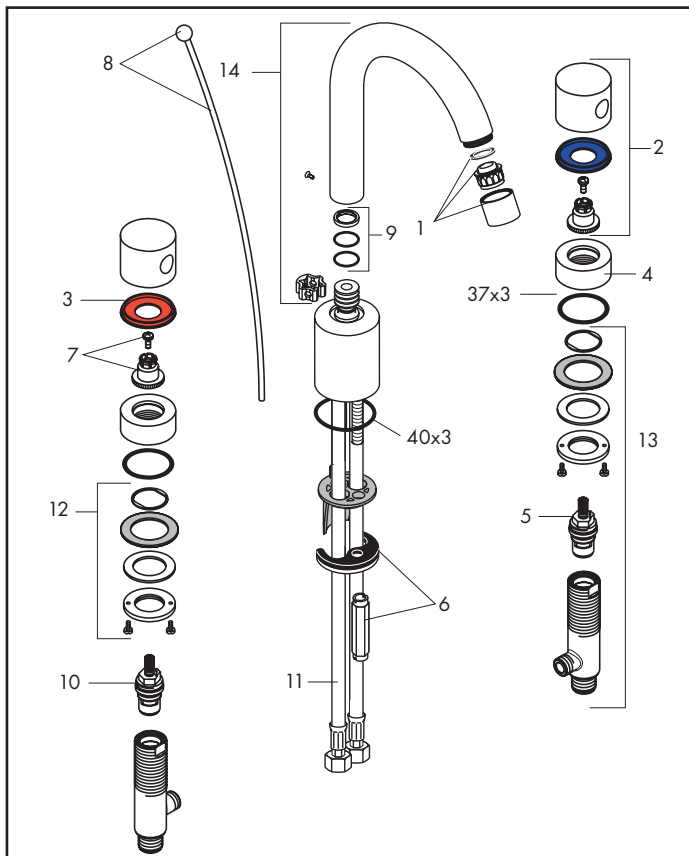

Pos.	Description	Description	Denominación	No./Nr./N°	PG
1	aerator	aérateur	aireador	95455xx0	1 99*
2	handle	poignée	manija	38092xx0	1 14*
3	color ring cold / hot	bague couleur eau chaude/froide	anillo frío/caliente	96422000	set 3
4	escutcheon	rosace	florón	96462xx0	1 12*
5	cold cartridge	mécanisme eau froide	montura agua fría	94008000	1 10
6	fixing set	fixation	set de fijación	96016000	1 9
7	handle fixing set	entraîneur + vis	anclaje para manija	94184000	1 2
8	pull rod	firette	tirador	92620xx0	1 9*
9	sealing set	set de joint plat	junta	92646000	set 6
10	cartridge right closing	mécanisme eau chaude	montura agua caliente	94009000	1 10
11	connection hose	flexible de raccordements	conexión flexible	88596000	1 7
12	fixing set	fixation	set de fijación	88511000	1 7
13	valve set	robinet d'arrêt	válvula completa	88503000	set 17
14	spout	bec lavabo	caño para lavabo	96521xx0	1 16*
	pop-up drain, see p. 4.171	vidage lavabo voir p. 4.171	vaciadores ver p. 4.171	94159xx0	1 14*

# Axor® Uno

3-Hole lavatory faucet / Robinet grande ecartement / Batéria americana para lavabo

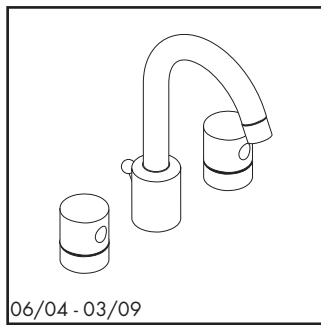

06/04 - 03/09

38033xx1

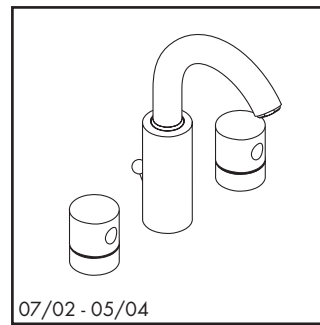
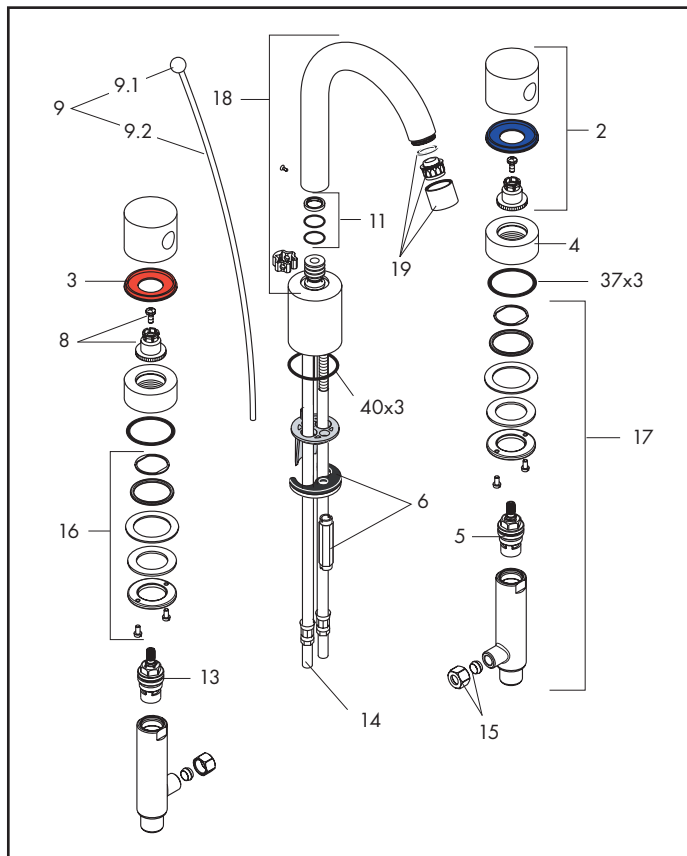

07/02 - 05/04

38033xx1

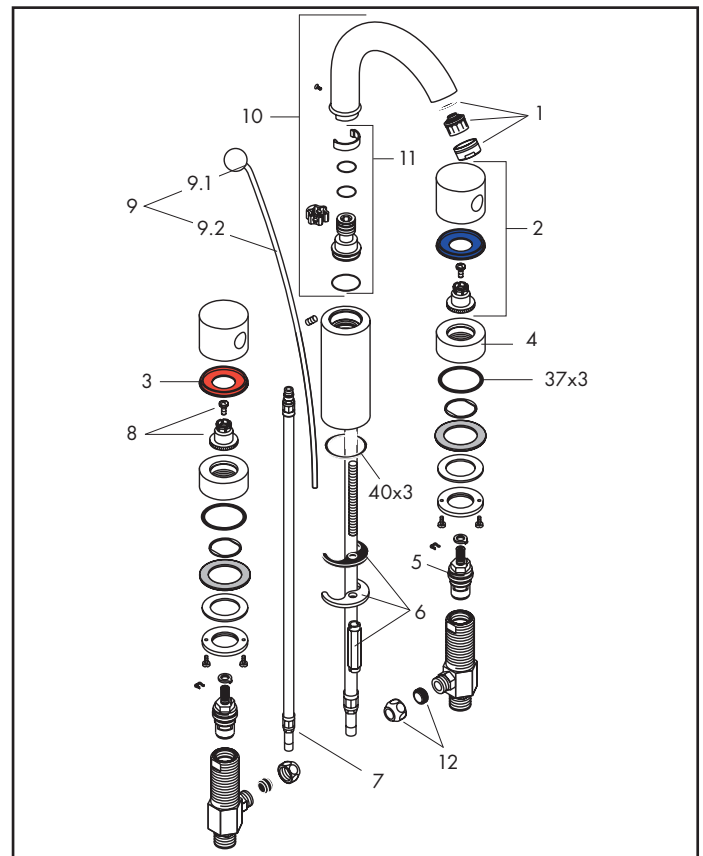

Pos.	Description	Description	Denominación	No./Nr./N°	PG
1	aerator	aérateur	aireador	13085xx0	1 4*
2	handle	poignée	manija	38092xx0	1 14*
3	color ring cold / hot	bague couleur eau chaude/froide	anillo frío/caliente	96422000	set 3
4	escutcheon	rosace	florón	96462xx0	1 12*
5	cold cartridge	mécanisme eau froide	montura agua fría	94008000	1 10
6	fixing set	fixation	set de fijación	96016000	1 9
7	connection hose 18"	flexible de raccordelements 18"	conexión flexible 18"	96321001	1 9
8	handle fixing set	entraîneur + vis	anclaje para manija	94184000	1 2
9	pull rod	tirette	tirador	92620xx0	1 9*
9.1	diverter knob	bouton d'inverseur	tirador inversor	94066xx0	1 99
9.2	pull rod	tirette	tirador	94067000	1 6*
10	spout large model	bec lavabo	caño para lavabo	92030xx0	1 16*
11	sealing set	set de joint plat	junta	92646000	set 6
12	compression fitting	raccord à bague sertie	tuercas grifería	94158000	set 3
13	cartridge right closing	mécanisme eau chaude	montura agua caliente	94009000	1 10
14	connection hose	flexible de raccordelements	conexión flexible	88596000	1 7
15	3/8 compression fittings (pair)	raccord à bague sertie 3/8 (2 pièces)	tuercas grifería 3/8 (2 pieza)	88513000	set 4
16	fixing set	fixation	set de fijación	88511000	1 7
17	valve set	robinet d'arrêt	válvula completa	88503000	set 17
18	spout	bec lavabo	caño para lavabo	96521xx0	1 16*
19	aerator	aérateur	aireador	94010xx0	1 4*
	pop-up drain, see p. 4.171	vidage lavabo voir p. 4.171	vaciadores ver p. 4.171	94159xx0	1 14*

**hansgrohe**

xx = Please see p. 4.1 for finish codes / \*PG is for Chrome only. See the index for other finishes.

xx = Description des codes couleur page 4.1 / \*PG concerne Chromé seulement. Pour les autres, voir dans la liste des références.

xx = Para el código de acabados ver p. 4.1 / \*La PG vale para Cromado solo. Ver el índice para las otras superficies.

4.111

6/2011



# Axor® Uno<sup>2</sup>

3-Hole lavatory faucet / Robinet grande écartement / Batéria americana para lavabo

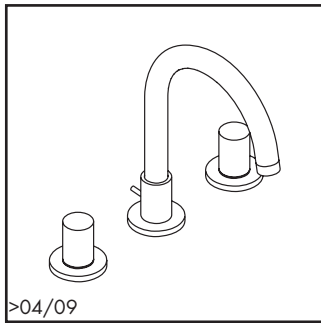

>04/09

38053xx1

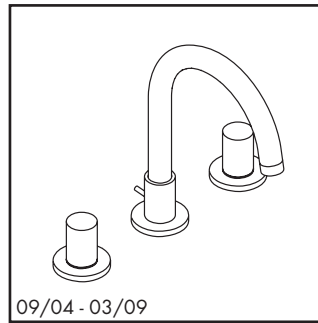

09/04 - 03/09

38053xx1

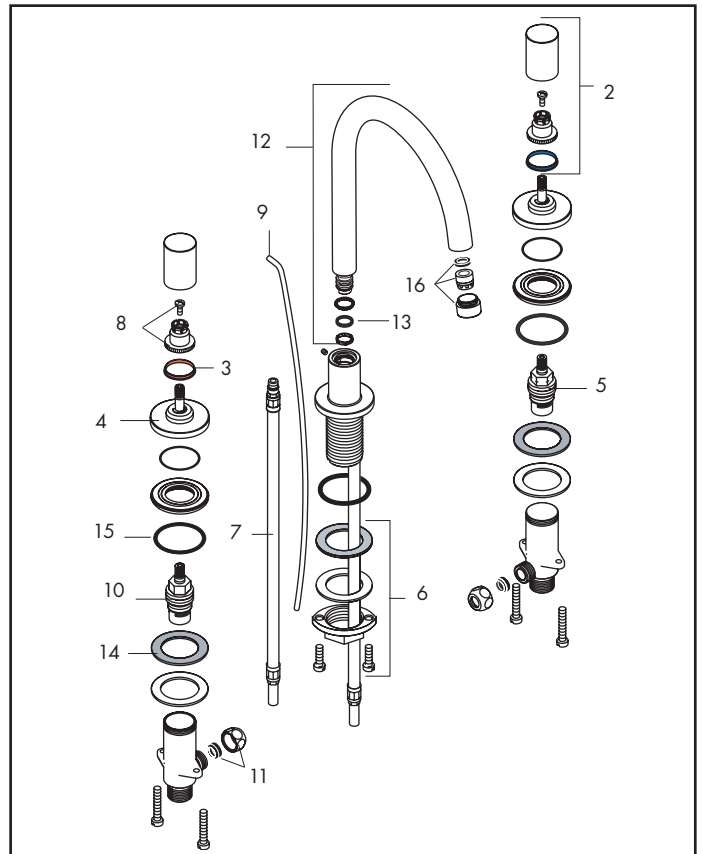
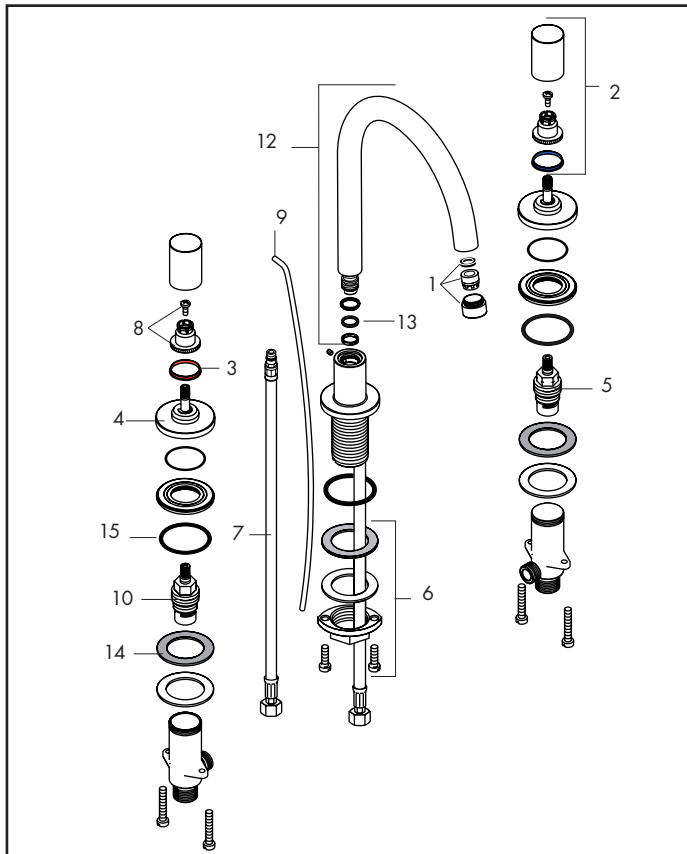

Pos.	Description	Description	Denominación	No./Nr./N°	PG
1	aerator	aérateur	aireador	95387xx0	1 99
2	handle	poignée	manija	38093xx0	1 13*
3	color ring cold / hot	bague couleur eau chaude/froide	anillo frío/caliente	96319000	set 3
4	escutcheon	rosace	embellecedor	97285xx0	1 11*
5	cold cartridge	mécanisme eau froide	montura agua fría	94008000	1 9
6	fixing set	fixation	set de fijación	13961000	1 7
7	connection hose	flexible de raccordement	conexión flexible	96321001	1 9
8	handle fixing set	entraîneur + vis	anclaje para manija	94184000	1 2
9	pull rod	tirette	tirador	96657xx0	1 4*
10	hot cartridge	mécanisme eau chaude	montura agua caliente	94009000	1 9
11	3/8 compression fittings (pair)	raccord à bague sertie 3/8 (2 pièces)	tuercas grifería 3/8 (2 pieza)	88513000	set 4
12	spout	bec lavabo	caño para lavabo	97363xx0	1 16*
13	O-ring 11x2 (pair)	joint torique 11x2 (2 pièces)	junta toroidal 11x2 (2 pieza)	98127000	set 1
14	lever collar	anneau plastique	arandela	97548000	1 1
15	O-ring 40x3	joint torique 40x3	junta toroidal 40x3	92634000	1 99
16	aerator	aérateur	aireador	96911xx0	1 9*
	pop-up drain, see p. 4.171	vidage lavabo voir p. 4.171	vaciadores ver p. 4.171	94159xx0	1 14*

4.112  
6/2011

xx = Please see p. 4.1 for finish codes / \*PG is for Chrome only. See the index for other finishes.  
xx = Description des codes couleur page 4.1 / \*PG concerne Chromé seulement. Pour les autres, voir dans la liste des références.  
xx = Para el código de acabados ver p. 4.1 / \*La PG vale para Cromado solo. Ver el índice para las otras superficies.

**hansgrohe**

# Axor® Uno

3-Hole lavatory faucet / Robinet grande ecartement / Batéria americana para lavabo

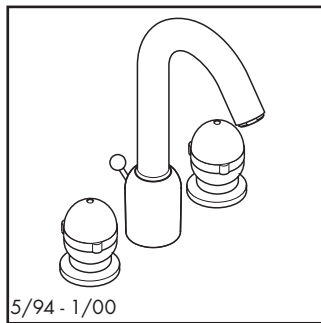

5/94 - 1/00

13033xx1

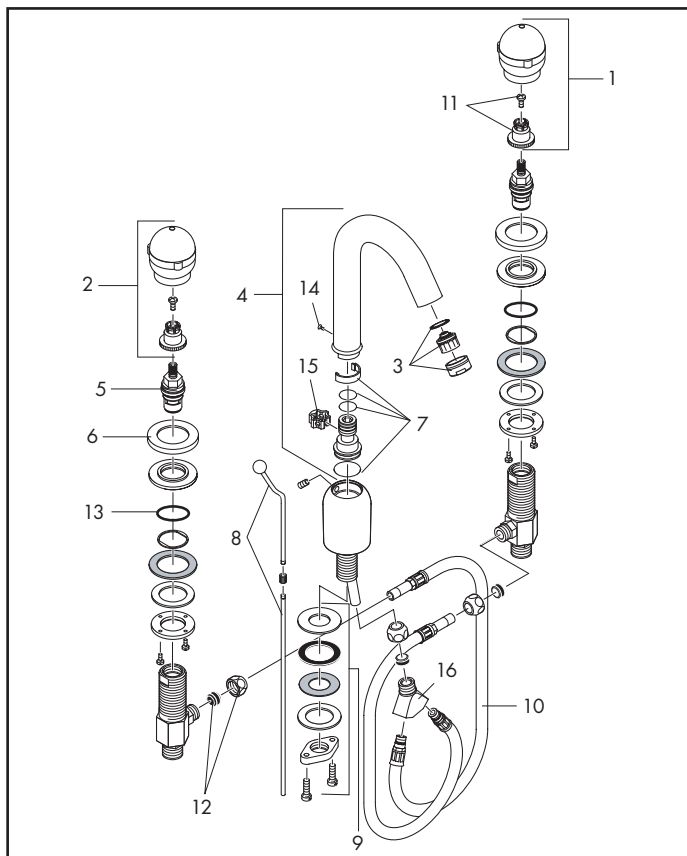

Pos.	Description	Description	Denominación	No./Nr./N°	PG
1	cold handle	poignée eau froide	manija agua fría	13291xx0	1 99
2	hot handle	poignée eau chaude	manija agua caliente	13292xx0	1 99
3	aerator	aérateur	aireador	13085xx0	1 4*
4	spout	bec	caño	92033xx0	1 99
5	Elastop cartridge	mécanisme arrêt	montura Elastop	94149000	1 9
6	escutcheon	rosace	embellecedor	94115xx0	1 6*
7	seal set	set de joint plat	junta	92646000	set 6
8	pull rod	tirette	tirador	92621xx0	1 99
9	fixing set	fixation	set de fijación	94702000	1 99
10	connecting hose	flexible de raccordement	conexión flexible	94071000	1 8
11	handle fixing set	entraîneur + vis	anclaje para manija	94184000	1 2
12	compression fitting	raccord à bague sertie	tuercas grifería	94158000	set 3
13	40x3 o-ring	joint torique 40x3	junta toroidal 40x3	92634000	1 99
14	screw	vis	tornillo	97662000	1 3
15	axial ring	anneau de axial	anillo axial	97558000	1 1
16	mounting angle	coude de raccordement flexible	rácor conexión flexo	97753000	1 10
	pop-up drain, see p. 4.171	vidage lavabo voir p. 4.171	vaciadores ver p. 4.171	94159xx0	1 14*

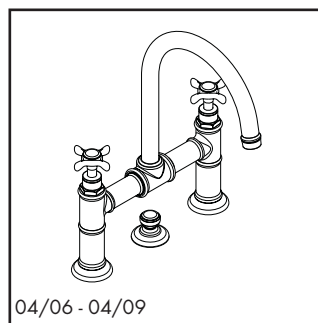
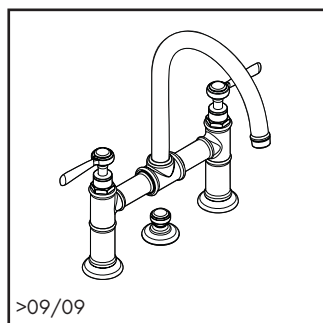
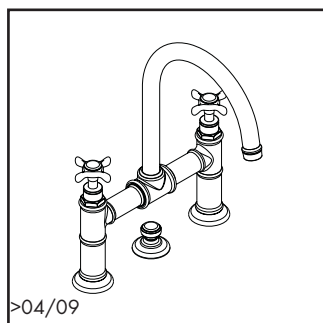

16510xx1

16511xx1

16510xx1

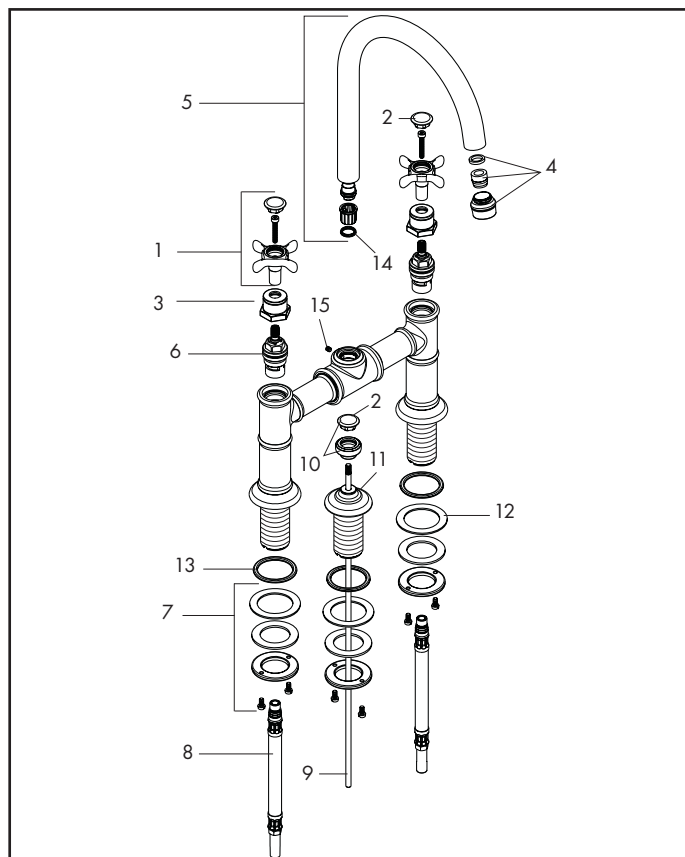
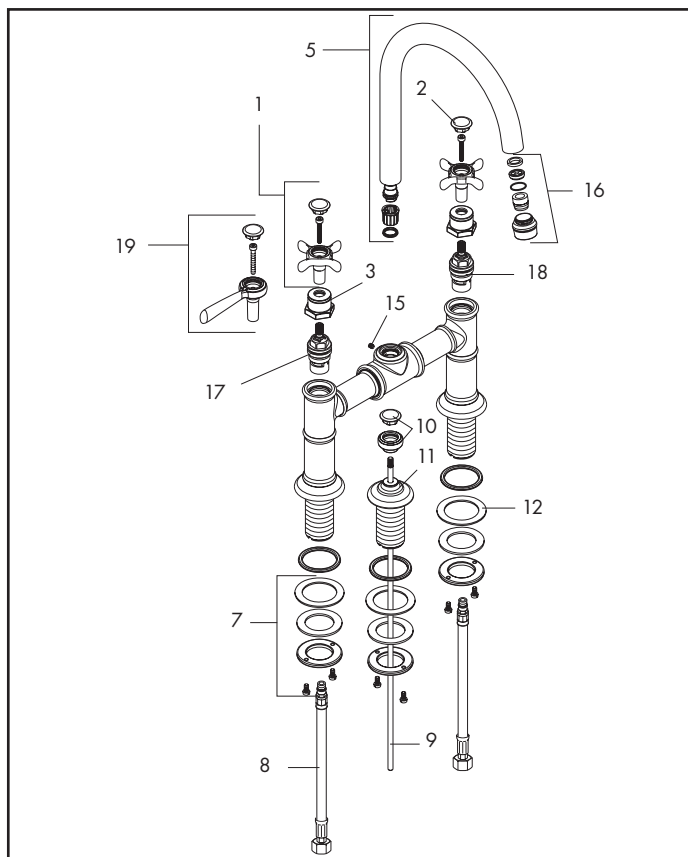

Pos.	Description	Description	Denominación	No./Nr./N°	PG
1	cross handle	poignée croisillon	manija en cruz	16597xx0	1 15*
2	screw cover cold / hot water	cache vis couleur eau chaude/froide	tapón frío /caliente	97987000	set 12
3	sleeve	douille	casquillo	97993xx0	1 99
4	aerator M18x1, 2.2 GPM	aérateur M18x1, 2.2 GPM	aireador M18x1, 2.2 GPM	97991xx0	1 13*
	aerator M18x1, 1.5 GPM	aérateur M18x1, 1.5 GPM	aireador M18x1, 1.5 GPM	95378xx0	1 99*
5	spout large model	bec lavabo	caño para lavabo	97990xx0	1 17*
6	cartridge	mécanisme	montura	94009000	1 10
7	fixing set for cartridge	fixation pour robinet d'arrêt	set de fijación para montura	96078000	1 9
8	connection hose 18"	flexible de raccordement 18"	conexión flexible 18"	14099001	1 9
9	pull rod	tirette	tirador	94067000	1 6
10	diverter knob	bouton d'inverseur	tirador inversor	98619xx0	1 12*
11	escutcheon	rosace	florón	98620xx0	1 15*
12	lever collar	anneau plastique	arandela	97548000	1 1
13	O-ring 34x4	joint torique 34x4	junta toroidal 34x4	98155000	1 1
14	O-ring 11x2 (2 pieces)	joint torique 11x2 (2 pièce)	junta toroidal 11x2 (2 pieza)	98127000	set 1
15	hollow set screw M4x5	vis M4x5	tornillo manecilla M4x5	98731000	1 11
16	aerator M18x1	aérateur M18x1	aireador M18x1	95378xx0	1 99
17	hot cartridge for lever handle	mécanisme eau chaude pour levier	montura agua caliente para palanca	96350001	1 10
	hot cartridge for cross handle	mécanisme eau chaude pour croisillon	montura agua caliente para cruz	94009000	1 10
18	cold cartridge for lever handle	mécanisme eau froide pour levier	montura agua fría para palanca	96351001	1 10
	cold cartridge for cross handle	mécanisme eau froide pour croisillon	montura agua fría para cruz	94008000	1 10
19	lever handle	poignée levier	manija tipo palanca	16691xx0	1 17*
	pop-up drain, see p. 4.171	vidage lavabo voir p. 4.171	vaciadores ver p. 4.171	94159xx0	1 14*

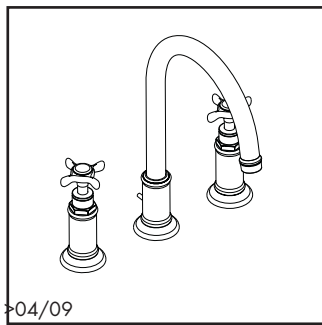

16513xx1

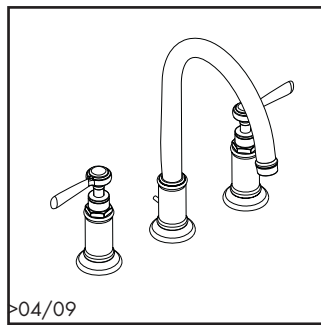

16514xx1

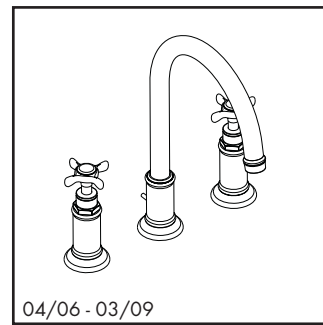

16513xx1

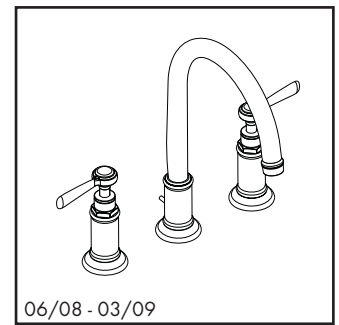

16514xx1

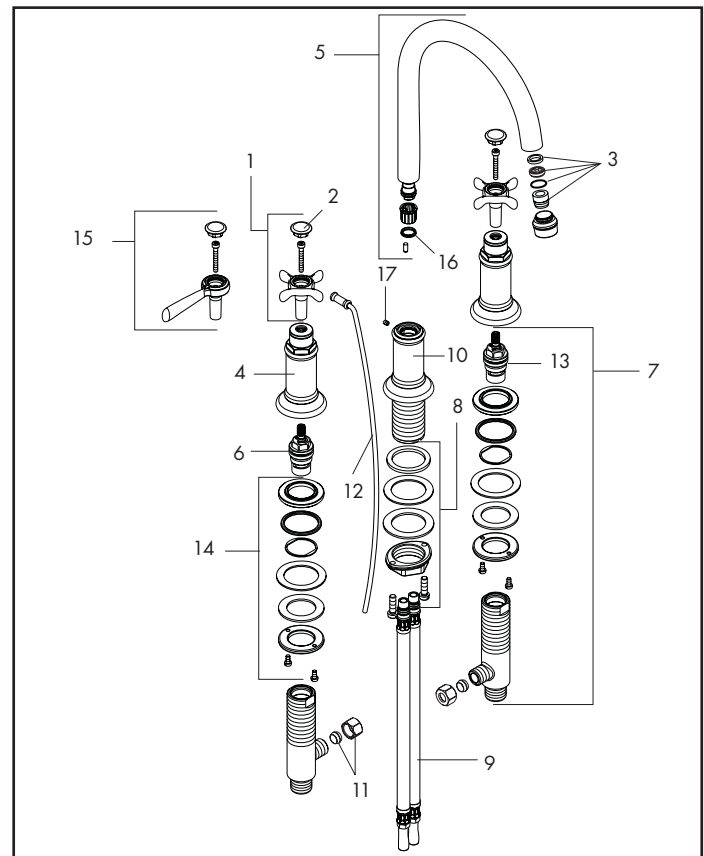
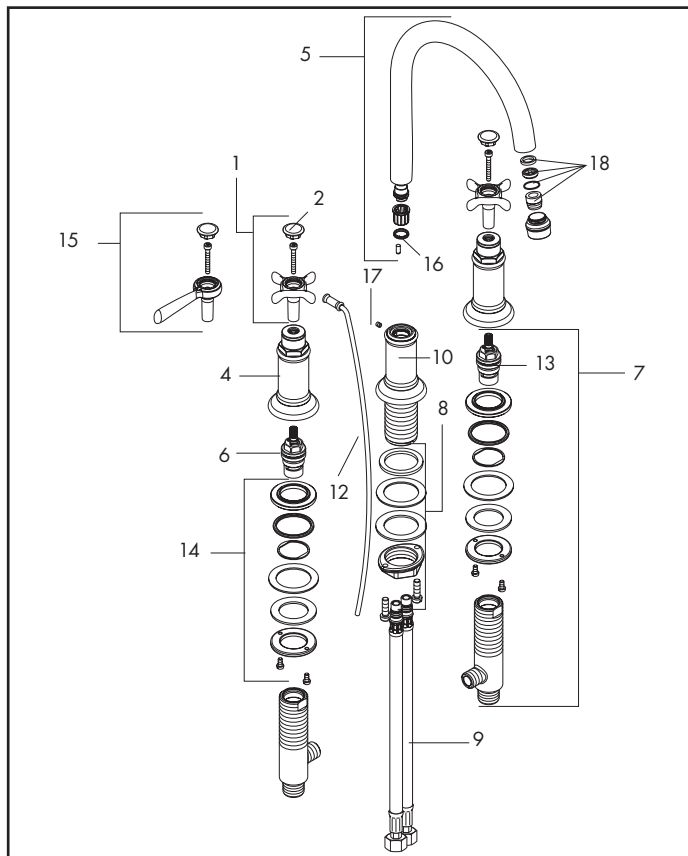

Pos.	Description	Description	Denominación	No./Nr./N°	PG
1	cross handle	poignée croisillon	manija en cruz	16291xx0	1 14*
2	screw cover cold / hot water	cache vis couleur eau chaude/froide	tapón frío /caliente	97987000	set 12
3	aerator M18x1, 2.2 GPM	aérateur M18x1, 2.2 GPM	aireador M18x1, 2.2 GPM	97991xx0	1 13*
	aerator M18x1, 1.5 GPM	aérateur M18x1, 1.5 GPM	aireador M18x1, 1.5 GPM	95378xx0	1 99*
4	handle escutcheon	rosace pour poignée	florón para manija	97988xx0	1 99
5	spout	bec	caño	97990xx0	1 17*
6	hot cartridge	mécanisme eau chaude	montura agua caliente	94009000	1 10
7	valve set	robinet d'arrêt	válvula completa	88503000	set 17
8	fixing set	set de fixation	adaptador set	13961000	1 7
9	connection hose	flexible de raccordement	conexión flexible	94071001	1 9
10	spout escutcheon	rosace pour bec	florón para caño	97989xx0	1 99
11	compression ftgs. (pair)	raccord à bague sertie (2 pièce)	tuerças grifería (2 pieza)	88513000	set 4
12	pull rod	tirette	tirador	96657000	1 4*
13	cold cartridge	mécanisme eau froid	montura agua fría	94008000	1 10
14	fixing set	set de fixation	adaptador set	88511000	1 7
15	lever handle	poignée levier	manija tipo palanca	16691xx0	1 17*
16	O-ring 11x2 (2 pieces)	joint torique 11x2 (2 pièce)	junta toroidal 11x2 (2 pieza)	98127000	set 1
17	hollow set screw M4x5	vis M4x5	tornillo manecilla M4x5	98731000	1 11
	pop-up drain, see p. 4.171	vidage lavabo voir p. 4.171	vaciadores ver p. 4.171	94159xx0	1 14*

# Axor® Terrano®

3-Hole lavatory faucet / Robinet grande ecartement / Batéria americana para lavabo

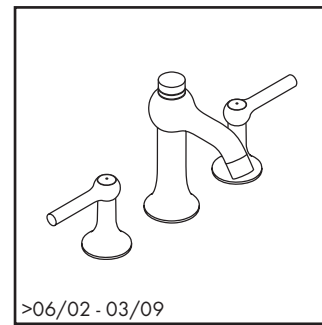
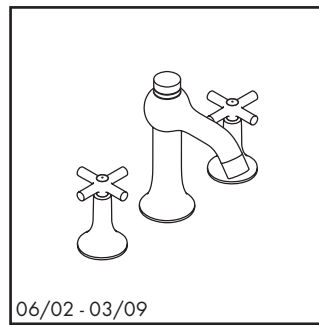
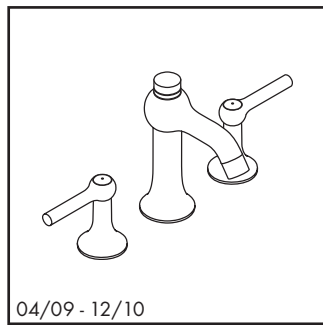
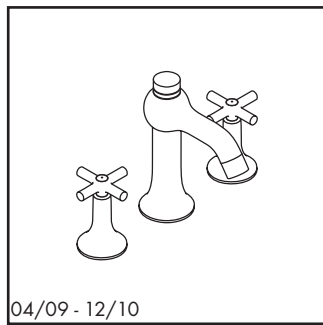

37133xx1

37135xx1

37133xx1

37135xx1

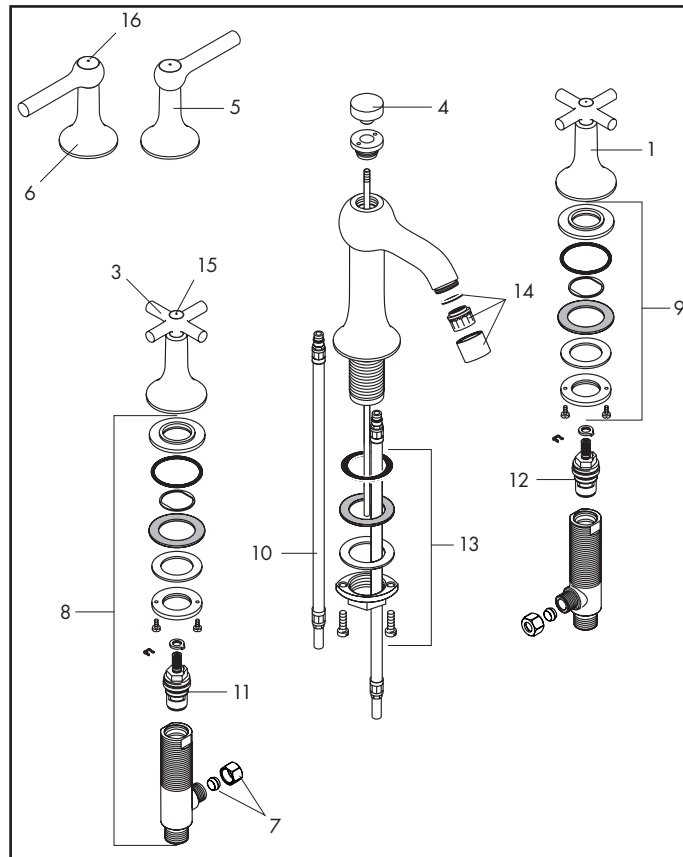
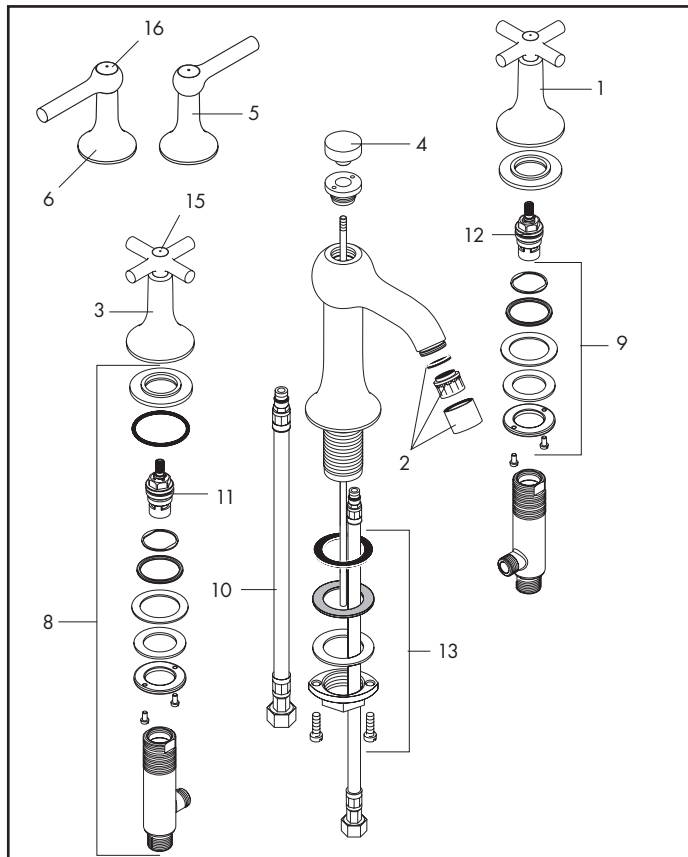

Pos.	Description	Description	Denominación	No./Nr./N°	PG
1	cross handle, cold	poignée croisillon, froide	manija en cruz, fría	37291xx0	1 16*
2	aerator	aérateur	aireador	95455xx0	1 99
3	cross handle, hot	poignée croisillon, chaude	manija en cruz, caliente	37292xx0	1 15*
4	diverter knob	bouton d'inverseur	tirador inversor	96335xx0	1 12*
5	lever handle, cold	poignée levier, froide	manija tipo palanca, fría	37296xx0	1 15*
6	lever handle, hot	poignée levier, chaude	manija tipo palanca, caliente	37295xx0	1 15*
7	3/8" compression fittings (pair)	raccord à bague sertie 3/8" (2 pièces)	tuercas grifería 3/8" (2 pieza)	88513000	set 4
8	valve set	robinet d'arrêt	válvula	88503000	set 17
9	fixing set	fixation	set de fijación	88511000	1 7
10	connection hose	flex. de raccordements	conexión flexible	94071001	1 7
11	hot cartridge	mécanisme eau chaude	montura agua caliente	94008000	1 10
12	cold cartridge	mécanisme eau froide	montura agua fría	94009000	1 10
13	fixing set	fixation	set de fijación	13961000	1 7
14	aerator	aérateur	aireador	94010xx0	1 10*
15	screw cover	cache vis	tapón	96481xx0	set 3*
16	screw cover	cache vis	tapón	97798xx0	set 99
	pop-up drain, see p. 4.171	vidage lavabo voir p. 4.171	vaciadores ver p. 4.171	94159xx0	1 14*

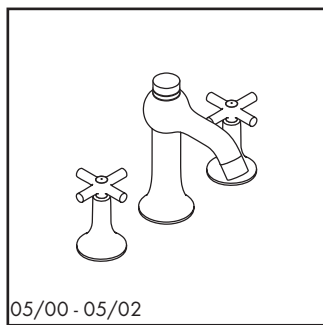

05/00 - 05/02

37133xx1

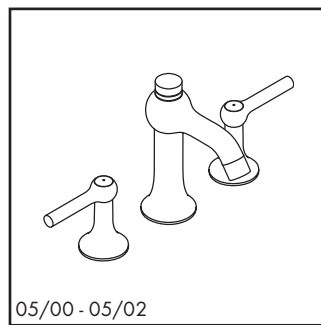

05/00 - 05/02

37135xx1

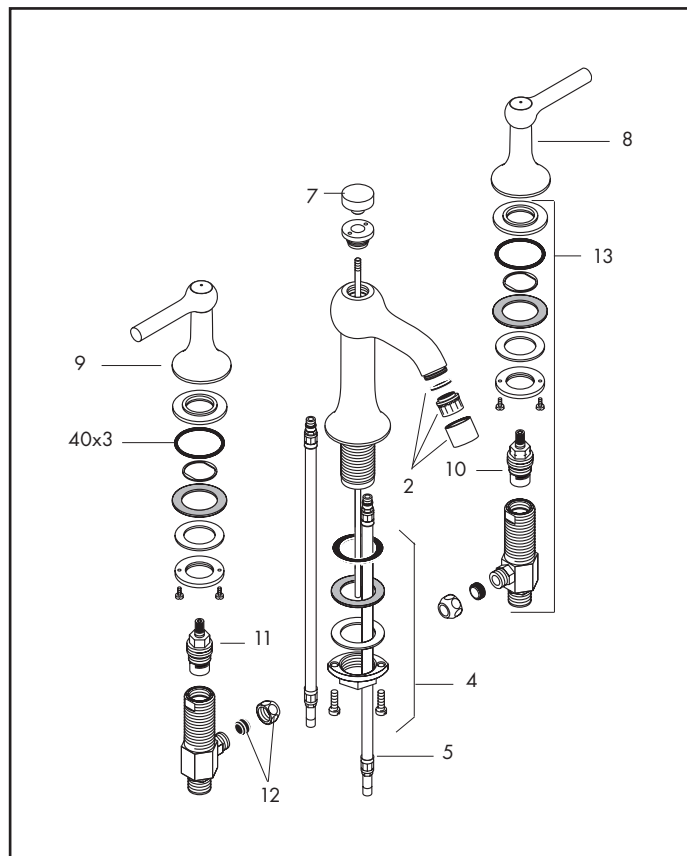
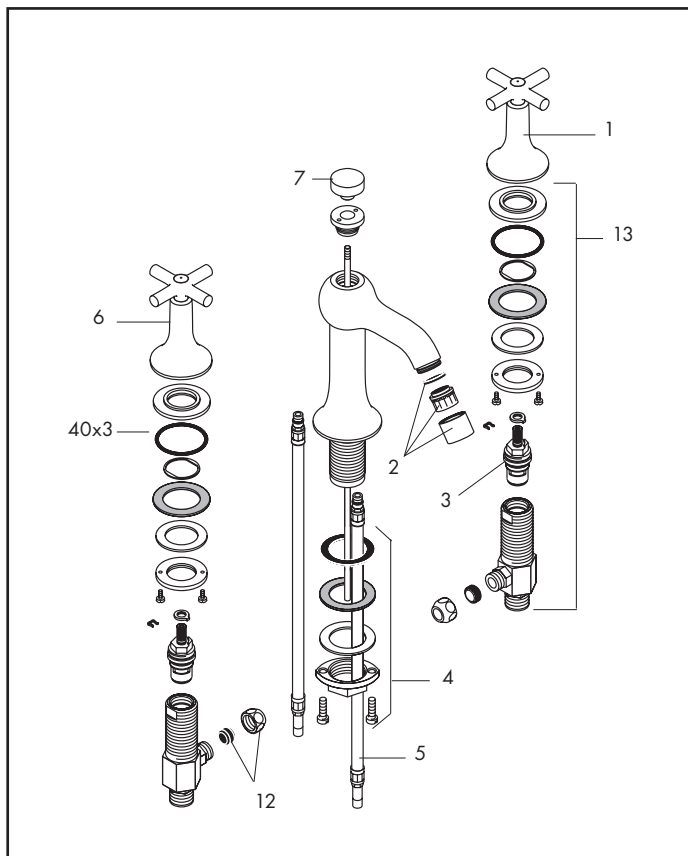

Pos.	Description	Description	Denominación	No./Nr./N°	PG
1	cross handle, cold	poignée croisillon, froide	manija en cruz, fría	37291xx0	1 16*
2	aerator	aérateur	aireador	94010xx0	1 10*
3	Elastop cartridge	mécanisme arrêt Elastop	montura Elastop	94149000	1 9
4	fixing set	fixation	set de fijación	13961000	1 7
5	connection hose 18"	flexible de raccordements 18"	conexión flexible 18"	96321001	1 9
6	cross handle, hot	poignée croisillon, chaude	manija en cruz, caliente	37292xx0	1 15*
7	diverter knob	bouton d'inverseur	tirador inversor	96335xx0	1 12*
8	lever handle, cold	poignée levier, froide	manija tipo palanca, fría	37296xx0	1 15*
9	lever handle, hot	poignée levier, chaude	manija tipo palanca, caliente	37295xx0	1 15*
10	cold cartridge	mécanisme eau froide	montura agua fría	96766000	1 11
11	hot cartridge	mécanisme eau chaude	montura agua caliente	96765000	1 11
12	compression fitting	raccord à bague sertie	tuerças grifería	94158000	set 3
13	stop valve	robinet d'arrêt	válvula	92933000	1 16
	pop-up drain, see p. 4.171	vidage lavabo voir p. 4.171	vaciadores ver p. 4.171	94159xx0	1 14*

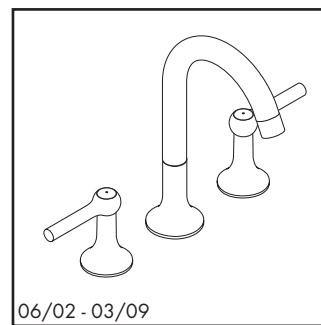
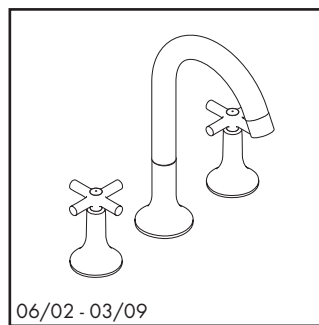
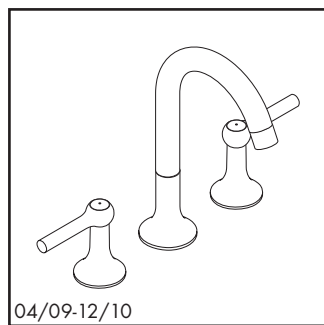
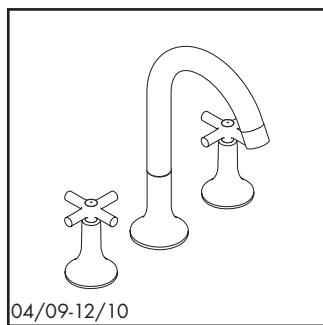

04/09-12/10  
37134xx1

04/09-12/10  
37136xx1

06/02 - 03/09  
37134xx1

06/02 - 03/09  
37136xx1

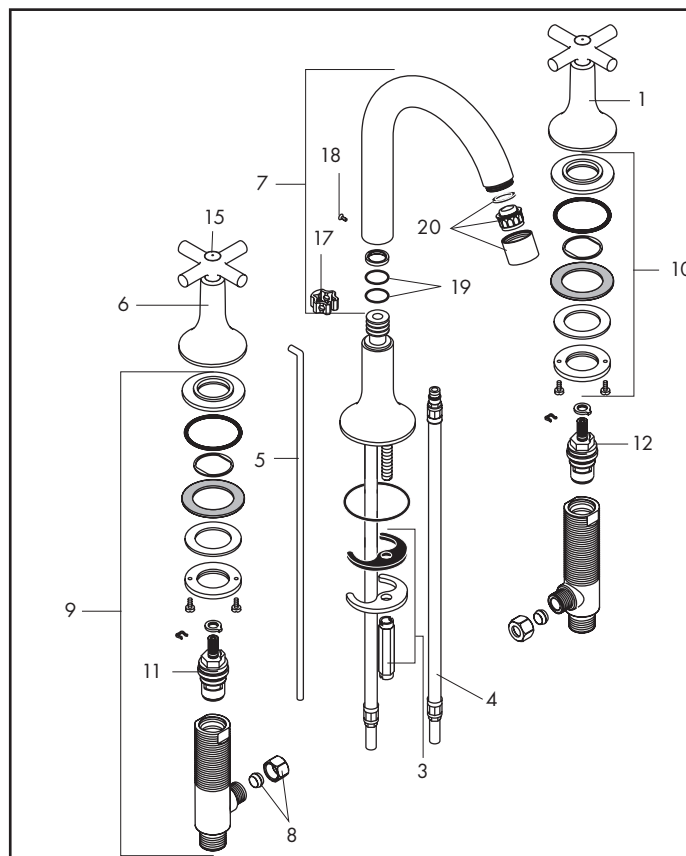
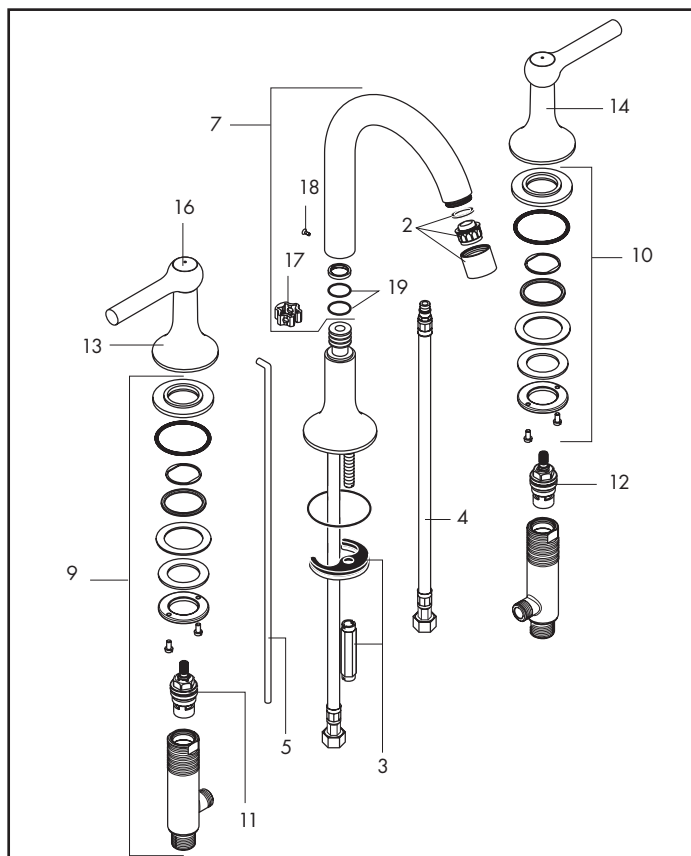

Pos.	Description	Description	Denominación	No./Nr./N°	PG
1	cross handle, cold	poignée croisillon, froide	manija en cruz, fría	37291xx0	1 16*
2	aerator	aérateur	aireador	95455000	1 99
3	fixing set	fixation	set de fijación	96016000	1 9
4	connection hose	flex. de raccords	conexión flexible	94071001	1 9
5	pull rod	tirette	tirador	94083xx0	1 9*
6	cross handle, hot	poignée croisillon, chaude	manija en cruz, caliente	37292xx0	1 15*
7	spout large model	bec lavabo	caño para lavabo	96521xx0	1 16*
8	3/8 compression fittings (pair)	raccord à bague sertie 3/8 (2 pièces)	tuercas grifería 3/8 (2 pieza)	88513000	set 4
9	valve set	robinet d'arrêt	válvula	88503000	set 17
10	fixing set	fixation	set de fijación	88511000	1 7
11	hot cartridge	mécanisme eau chaude	montura agua caliente	94008000	1 10
12	cold cartridge	mécanisme eau froide	montura agua fría	94009000	1 10
13	lever handle, cold	poignée levier, froide	manija tipo palanca, fría	37296xx0	1 15*
14	lever handle, hot	poignée levier, chaude	manija tipo palanca, caliente	37295xx0	1 15*
15	screw cover, hot/cold	cache vis chaude / froide	tapón caliente / fría	96481xx0	set 3*
16	screw cover, hot/cold	cache vis chaude /froide	tapón caliente / fría	97798xx0	set 99
17	axial ring	anneau de axial	anillo axial	97558000	1 1
18	screw	vis	tornillo	97662000	1 3
19	O-ring 14x2.5	joint torique 14x2.5	junta toroidal 14x2.5	98189000	1 1
20	aerator	aérateur	aireador	94010xx0	1 10*
	pop-up drain, see p. 4.171	vidage lavabo voir p. 4.171	vaciadores ver p. 4.171	94159xx0	1 14*

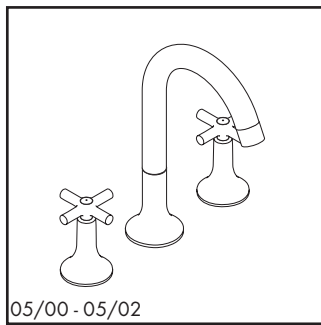

37134xx1

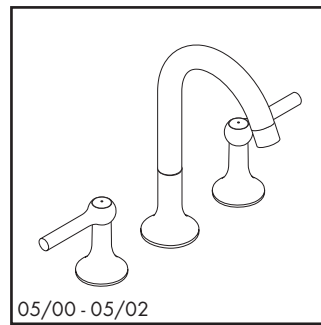

37136xx1

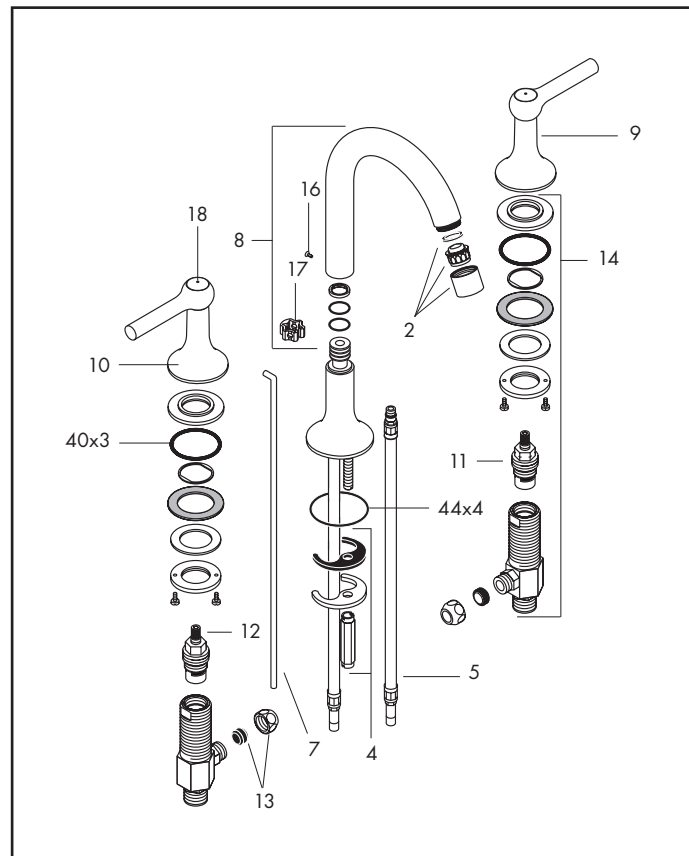
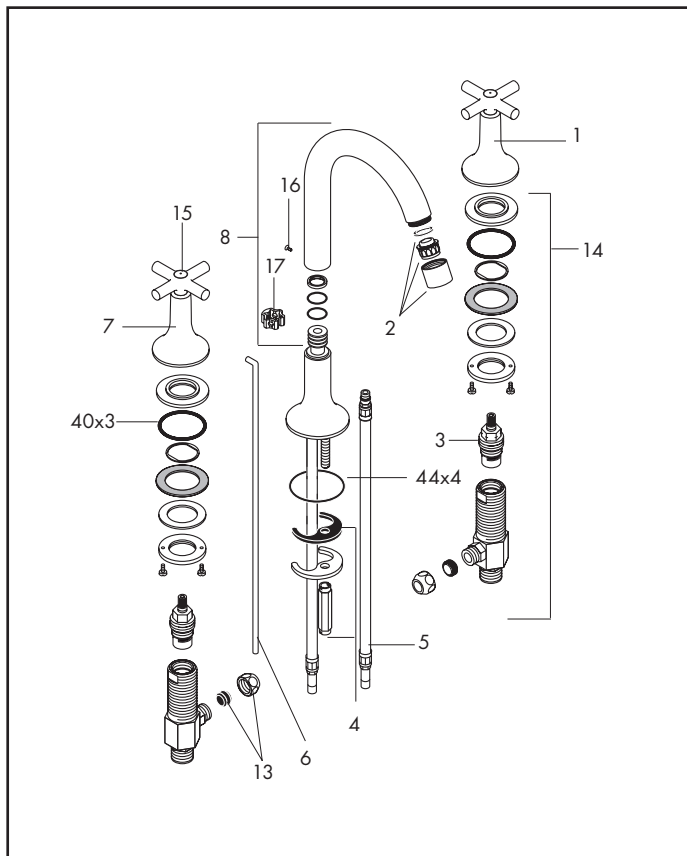

Pos.	Description	Description	Denominación	No./Nr./N°	PG
1	cross handle, cold	poignée croisillon, froide	manija en cruz, fría	37291xx0	1 16*
2	aerator	aérateur	aireador	94010xx0	1 10*
3	Elastop cartridge	mécanisme arrêt elastop	montura Elastop	94149000	1 9
4	fixing set	fixation	set de fijación	96016000	1 9
5	connection hose 18" < 6/96	flex. de raccords 18" < 6/96	conexión flexible 18" < 6/96	88596000	1 7
6	pull rod	tirette	tirador	94083xx0	1 9*
7	cross handle, hot	poignée croisillon, chaude	manija en cruz, caliente	37292xx0	1 15*
8	spout	bec lavabo	caño para lavabo	96521xx0	1 16*
9	lever handle, cold	poignée levier, froide	manija tipo palanca, fría	37296xx0	1 15*
10	lever handle, hot	poignée levier, chaude	manija tipo palanca, caliente	37295xx0	1 15*
11	cold cartridge	mécanisme eau froide	montura agua fría	96766000	1 11
12	hot cartridge	mécanisme eau chaude	montura agua caliente	96765000	1 11
13	compression fitting	raccord à bague sertie	tueras grifería	94158000	set 3
14	valve	robinet d'arrêt	válvula	92933000	1 16
15	screw cover	cache-vis	tapón	96481xx0	set 3*
16	screw	vis	tornillo	97662000	1 3
17	axial ring	bague axiale	anillo assiale	97558000	1 1
18	screw cover	cache-vis	tapón	97798xx0	set 99
	pop-up drain, see p. 4.171	vidage lavabo voir p. 4.171	vaciadores ver p. 4.171	94159xx0	1 14*



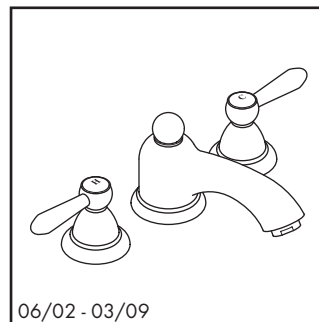
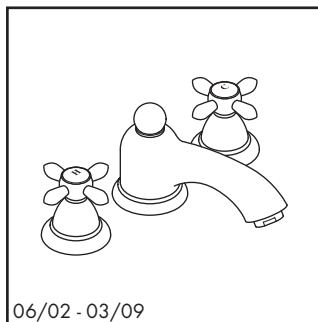
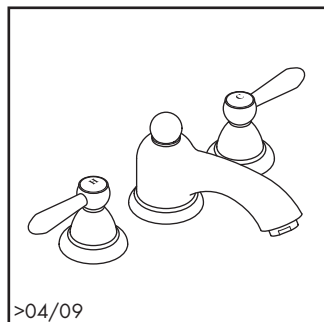
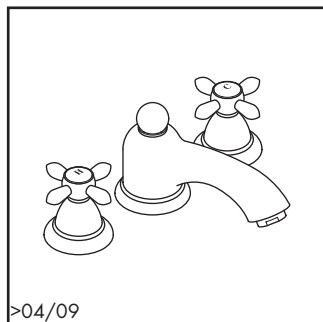

>04/09

>04/09

06/02 - 03/09

06/02 - 03/09

17133xx1

17135xx1

17133xx1

17135xx1

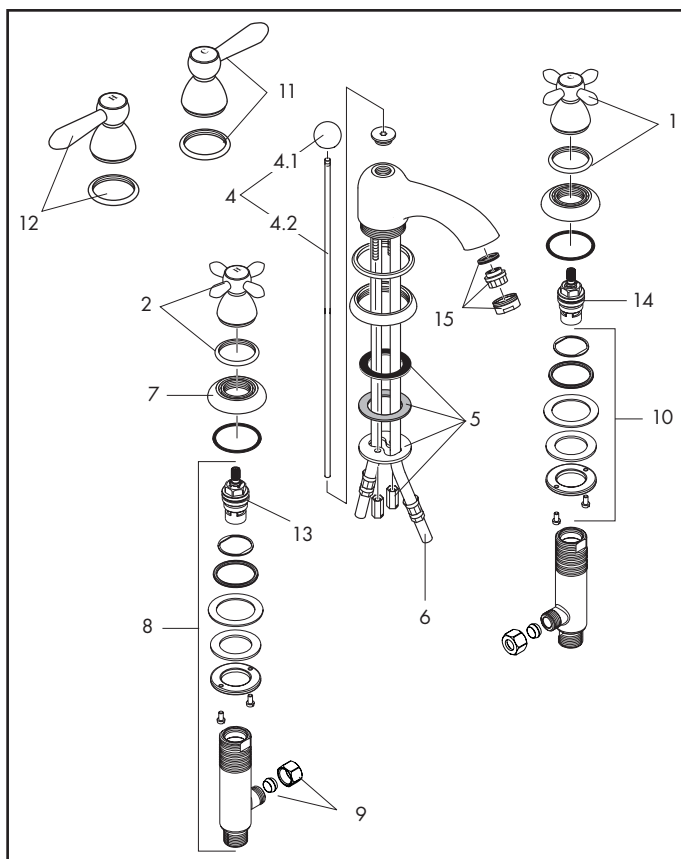
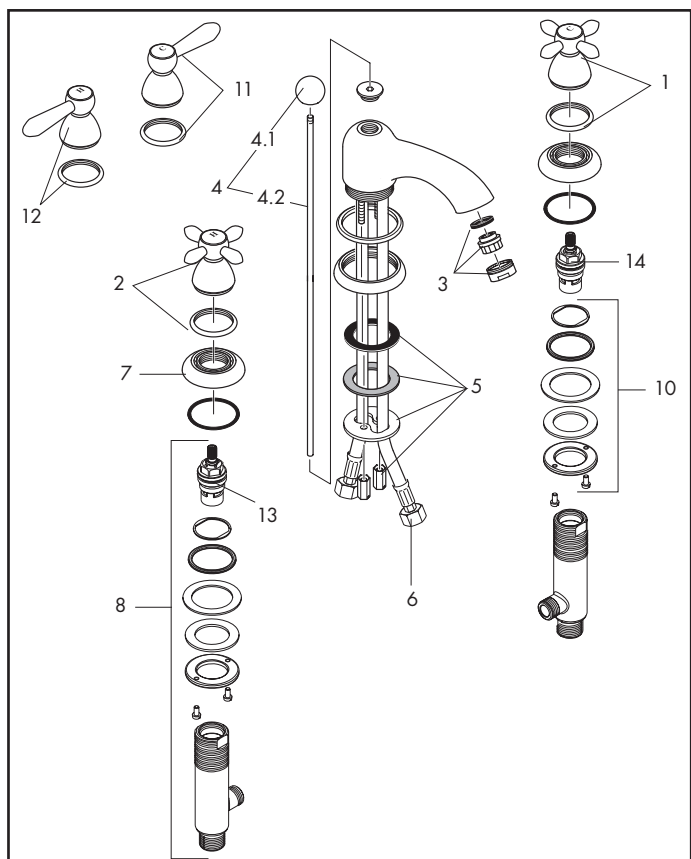

Pos.	Description	Description	Denominación	No./Nr./N°	PG
1	cross handle, cold	poignée croisillon, froide	manija en cruz, fría	17291xx0	1 14*
2	cross handle, hot	poignée croisillon, chaude	manija en cruz, caliente	17292xx0	1 14*
3	aerator	aérateur	aireador	13185xx0	1 8*
4	pull rod	tirette	tirador	94028xx0	1 9*
4.1	diverter knob	bouton d'inverseur	tirador inversor	94086xx0	1 6*
4.2	pull rod	tirette	tirador	94085000	1 9
5	fixing set	fixation	set de fijación	94138000	1 10
6	connection hose 18"	flex. de raccordements	conexión flexible	88596000	1 7
7	handle escutcheon	rosace pour poignée	florón para manija	94035xx0	1 9*
8	stop valve	robinet d'arrêt	válvula completa	88503000	set 17
9	3/8 compression fittings (pair)	raccord à bague sertie 3/8 (2 pièces)	tuercas grifería 3/8 (2 pieza)	88513000	set 4
10	fixing set	fixation	set de fijación	88511000	1 7
11	lever handle, cold	poignée levier, froide	manija tipo palanca, fría	17296xx0	1 17*
12	lever handle, hot	poignée levier, chaude	manija tipo palanca, caliente	17295xx0	1 17*
13	hot cartridge	mécanisme eau chaude	montura agua caliente	94009000	1 10
14	cold cartridge	mécanisme eau froide	montura agua fría	94008000	1 10
15	aerator	aérateur	aireador	13085xx0	1 4*
	pop-up drain, see p. 4.171	vidage lavabo voir p. 4.171	vaciadores ver p. 4.171	94159xx0	1 14*

4.120 xx = Please see p. 4.1 for finish codes / \*PG is for Chrome only. See the index for other finishes.

6/2011 xx = Description des codes couleur page 4.1 / \*PG concerne Chromé seulement. Pour les autres, voir dans la liste des références.

xx = Para el código de acabados ver p. 4.1 / \*La PG vale para Cromado solo. Ver el índice para las otras superficies.

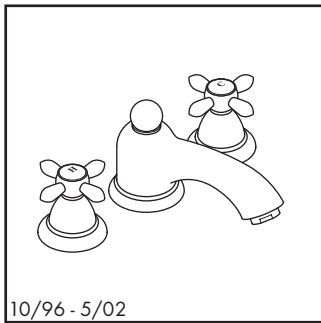

10/96 - 5/02

17133xx1

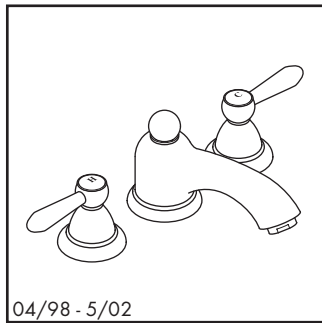

04/98 - 5/02

17135xx1

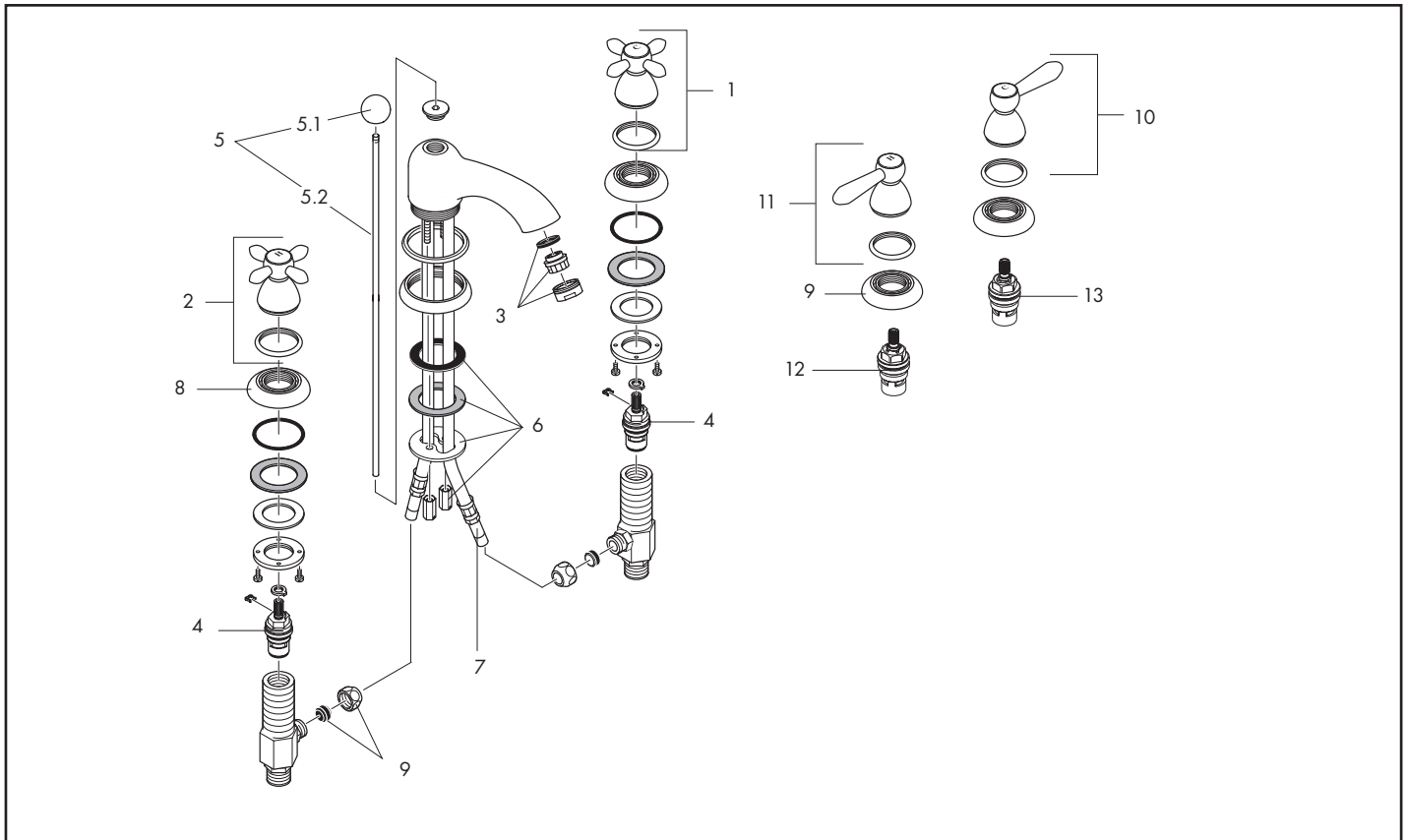

Pos.	Description	Description	Denominación	No./Nr./N°	PG
1	cross handle, cold	poignée croisillon, froide	manija en cruz, fría	17291xx0	1 14*
2	cross handle, hot	poignée croisillon, chaude	manija en cruz, caliente	17292xx0	1 14*
3	aerator	aérateur	aireador	13085xx0	1 4*
4	Elastop cartridge	mécanisme arrêt Elastop	montura Elastop	94149000	1 9
5	pull rod	tirette	tirador	94028xx0	1 9*
5.1	diverter knob	bouton d'inverseur	tirador inversor	94086xx0	1 6*
5.2	pull rod	tirette	tirador	94085000	1 9
6	fixing set	fixation	set de fijación	94138000	1 10
7	connection hose 18"	flex. de raccordements 18"	conexión flexible 18"	94071000	1 8
8	handle escutcheon	rosace pour poignée	florón para manija	94035xx0	1 9*
9	squeezing connection	raccord a bague sertie	tuercas giferia	94158000	set 3
10	lever handle, cold	poignée levier, froide	manija tipo palanca, fría	17296xx0	1 17*
11	lever handle, hot	poignée levier, chaude	manija tipo palanca, caliente	17295xx0	1 17*
12	hot cartridge	mécanisme eau chaude	montura agua caliente	94009000	1 10
13	cold cartridge	mécanisme eau froide	montura agua fría	94008000	1 10
	pop-up drain, see p. 4.171	vidage lavabo voir p. 4.171	vaciadores ver p. 4.171	94159xx0	1 14*

# Axor® Phoenix

3-Hole lavatory faucet / Robinet grande écartement / Batéria americana para lavabo

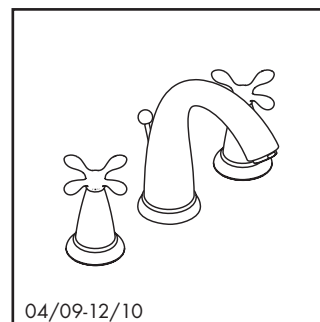
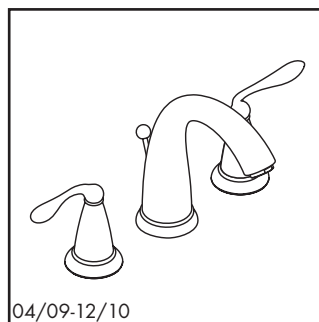
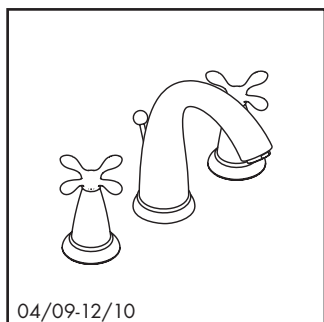
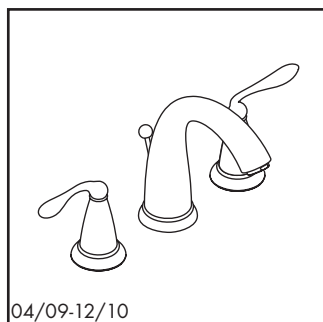

04/09-12/10  
17105xx1

04/09-12/10  
17104xx1

04/09-12/10  
17115xx1

04/09-12/10  
17114xx1

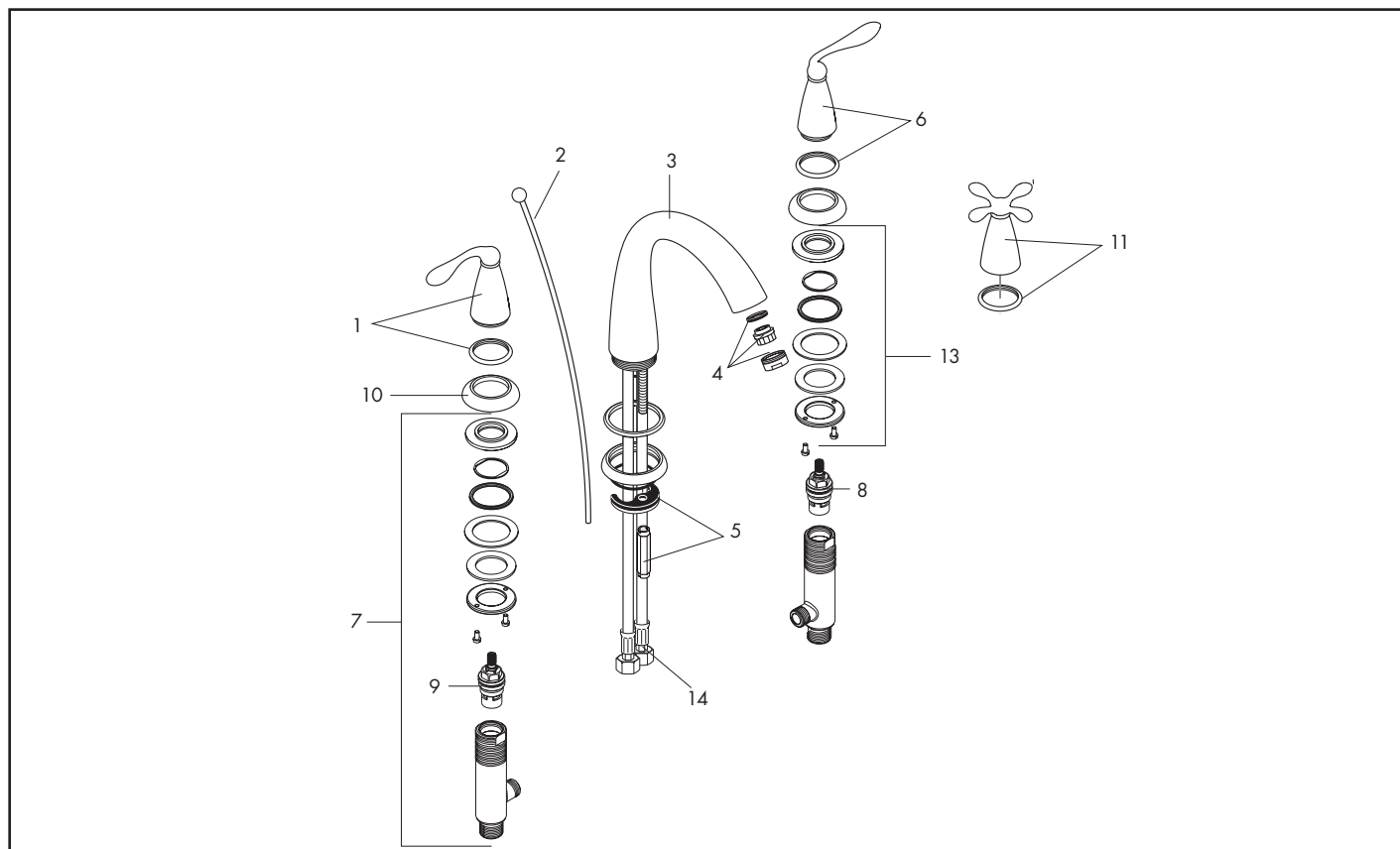

Pos.	Description	Description	Denominación	No./Nr./N°	PG
1	lever handle, hot	poignée levier, chaude	manija tipo palanca, caliente	96628xx1	1 14*
2	pop up rod	tirette	tirador	92620xx0	1 9*
3	spout, 5"	bec, 5"	caño, 5"	97805xx1	1 15*
	spout, 8"	bec, 8"	caño, 8"	97801xx1	1 16*
4	aerator	aérateur	aireador	13185xx0	1 8*
5	mounting set	set de fixation	set de fijación	96016000	1 9
6	lever handle, cold	poignée levier, froide	manija tipo palanca, fría	96629xx1	1 14*
7	stop valve	robinet d'arrêt	válvula	88503000	set 17
8	cold cartridge	mécanisme eau froide	montura agua fría	94008000	1 10
9	hot cartridge	mécanisme eau chaude	montura agua caliente	94009000	1 10
10	escutcheon	rosace	florón	94035xx0	1 9*
11	cross handle	poignée croisillon	manija en cruz	96793xx1	1 99
12	3/8 compression fittings (pair)	raccord à bague sertie 3/8 (2 pièces)	tuercas grifería 3/8 (2 pieza)	88513000	set 4
13	fixing set	set de fixation	set de fijación	88511000	1 7
14	connecting hose	flex. de raccordements	conexión flexible	94071001	1 9
	pop-up drain, see p. 4.171	vidage lavabo voir p. 4.171	vaciadores ver p. 4.171	94159xx0	1 14*

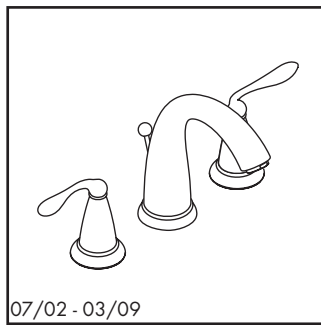

17105xx1

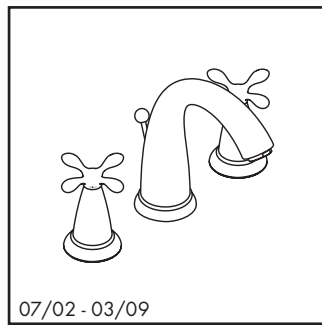

17104xx1

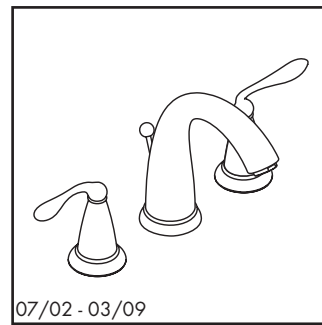

17115xx1

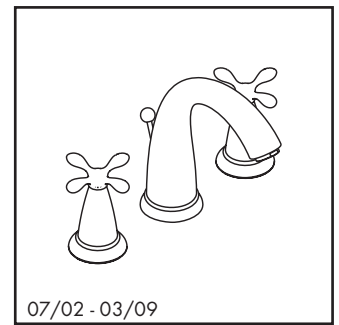

17114xx1

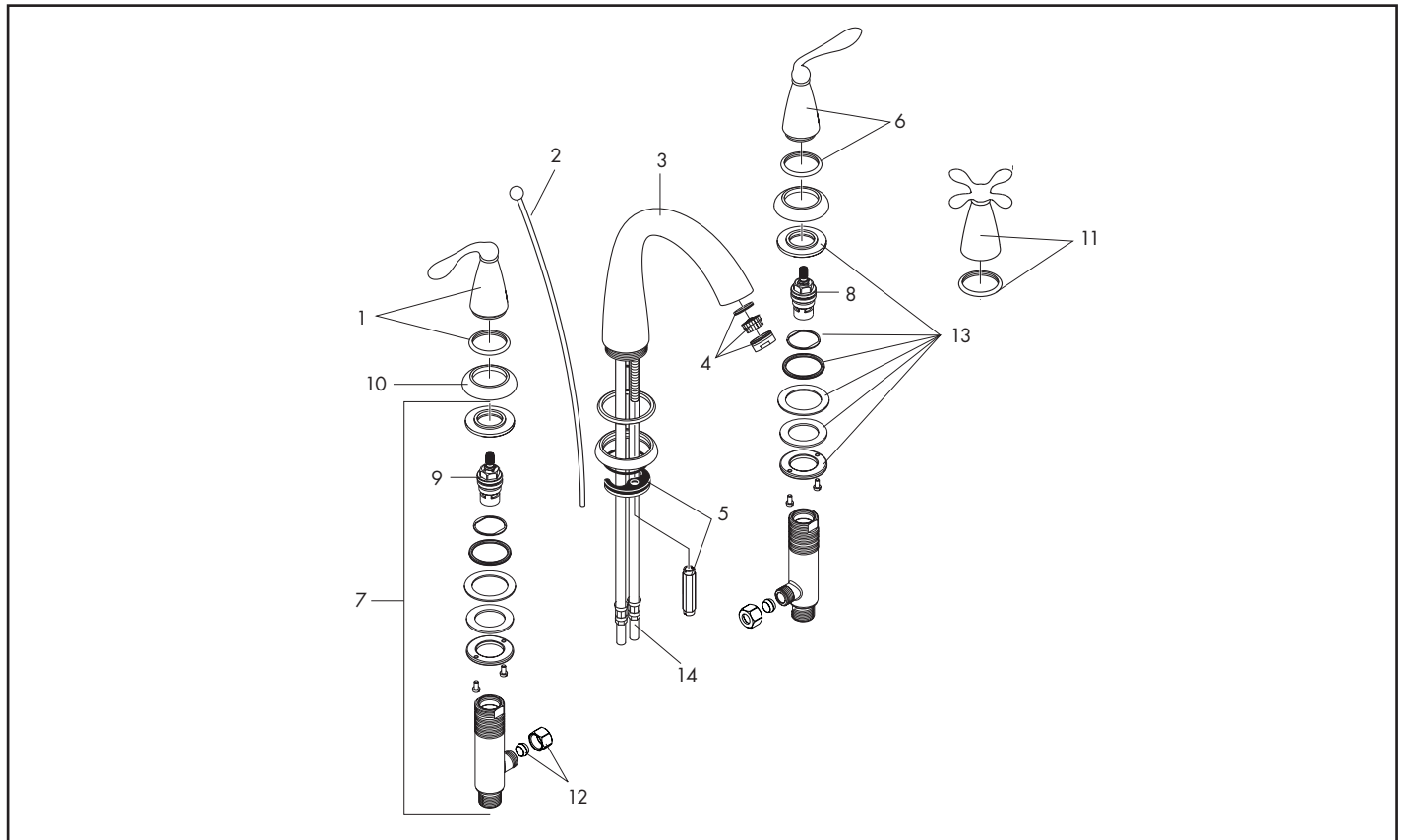

Pos.	Description	Description	Denominación	No./Nr./N°	PG
1	lever handle, hot	poignée levier, chaude	manija tipo palanca, caliente	96628xx1	1 14*
2	pop up rod	tirette	tirador	92620xx0	1 9*
3	spout, 5"	bec, 5"	caño, 5"	97805xx1	1 15*
	spout, 8"	bec, 8"	caño, 8"	97801xx1	1 16*
4	aerator	aérateur	aireador	13085xx0	1 4*
5	mounting set	set de fixation	set de fijación	96016000	1 9
6	lever handle, cold	poignée levier, froide	manija tipo palanca, fría	96629xx1	1 14*
7	stop valve	robinet d'arrêt	válvula	88503000	set 17
8	cold cartridge	mécanisme eau froide	montura agua fría	94008000	1 10
9	hot cartridge	mécanisme eau chaude	montura agua caliente	94009000	1 10
10	escutcheon	rosace	florón	94035xx0	1 9*
11	cross handle	poignée croisillon	manija en cruz	96793xx1	1 99
12	3/8 compression fittings (pair)	raccord à bague sertie 3/8 (2 pièces)	tueras grifería 3/8 (2 pieza)	88513000	set 4
13	fixing set	set de fixation	set de fijación	88511000	1 7
14	connecting hose	flex. de raccordements	conexión flexible	88596000	1 7
	pop-up drain, see p. 4.171	vidage lavabo voir p. 4.171	vaciadores ver p. 4.171	94159xx0	1 14*

# Axor® Allegroh

3-Hole lavatory faucet / Robinet grande écartement / Batería americana para lavabo

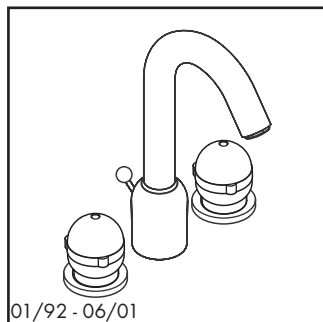

01/92 - 06/01

16033xx1

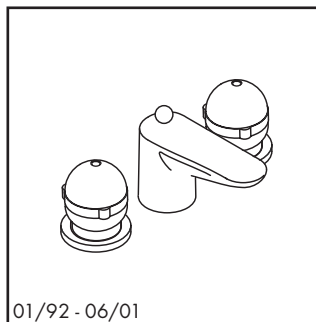

01/92 - 06/01

16133xx1

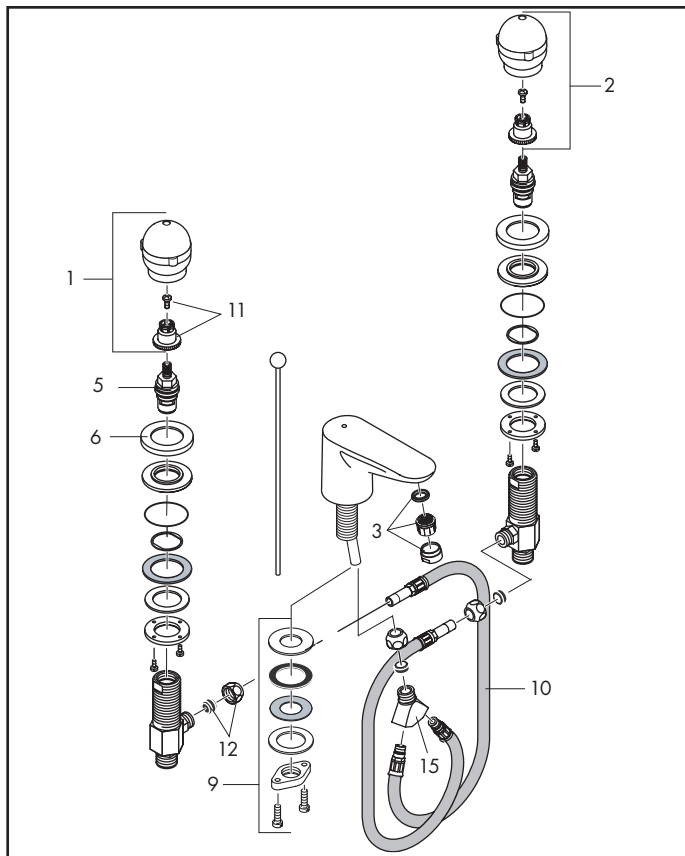
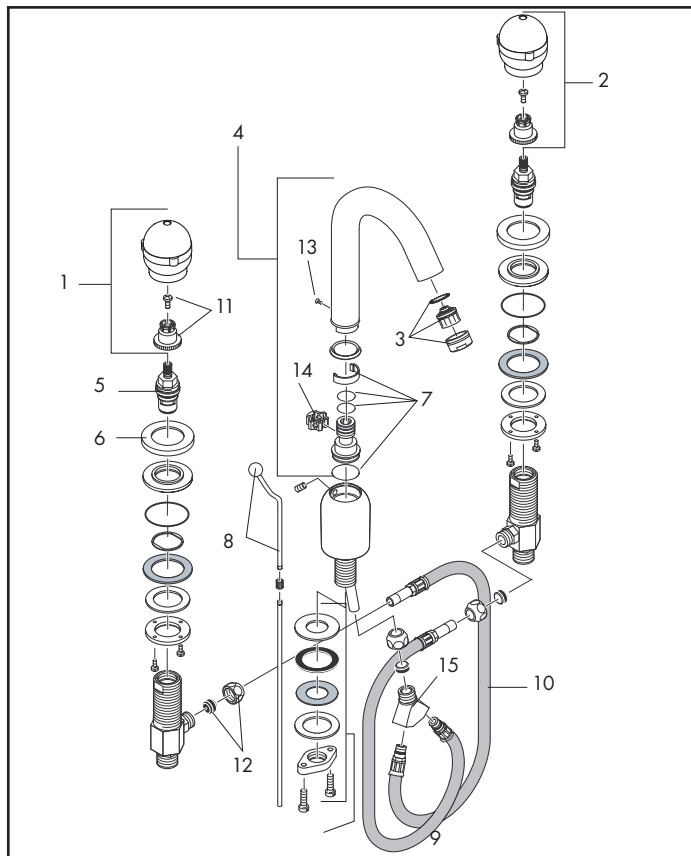

Pos.	Description	Description	Denominación	No./Nr./N°	PG
1	hot handle	poignée pour l'eau chaude	manija para agua caliente	94111xx0	1 99
2	cold handle	poignée pour l'eau froide	manija para agua fría	94110xx0	1 99
3	aerator	aérateur	aireador	13912xx0	1 4*
4	spout	bec	caño	95030xx0	1 99
5	Elastop cartridge	mécanisme arrêt Elastop	montura Elastop	94149000	1 9
6	escutcheon	rosace	florón	94115xx0	1 6*
7	sealing set	set de joints	set de juntas	92646000	set 6
8	pull rod and knob	tirette	firador	92621xx0	1 99
9	spout fixing set	fixation	set de fijación	94702000	1 99
10	connection hose	flexible de raccordement	conexión flexible	94071000	1 8
11	handle fixing set	entraîneur + vis	anclaje para manija	94184000	1 2
12	compression fitting	raccord à bague sertie	tuercas grifería	94158000	set 3
13	screw	vis	tornillo	97662000	1 3
14	axial ring	anneau de axial	anillo axial	97558000	1 1
15	hose connection angle	coude de raccordement flexible	rácór conexión flexo	97753000	1 10
	pop-up drain, see p. 4.171	vidage lavabo voir p. 4.171	vaciadores ver p. 4.171	94159xx0	1 14*

# Axor® Allegroh

3-Hole lavatory faucet / Robinet grande ecartement / Batéria americana para lavabo

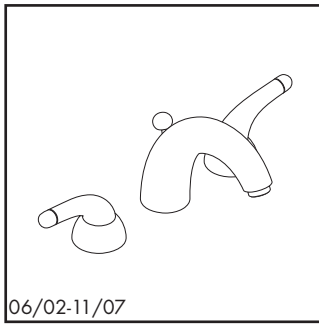

06/02-11/07

36135xx1

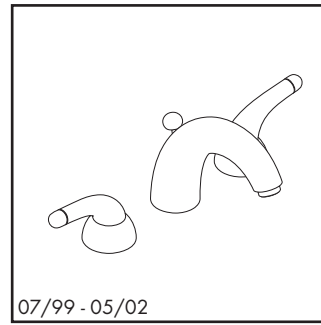
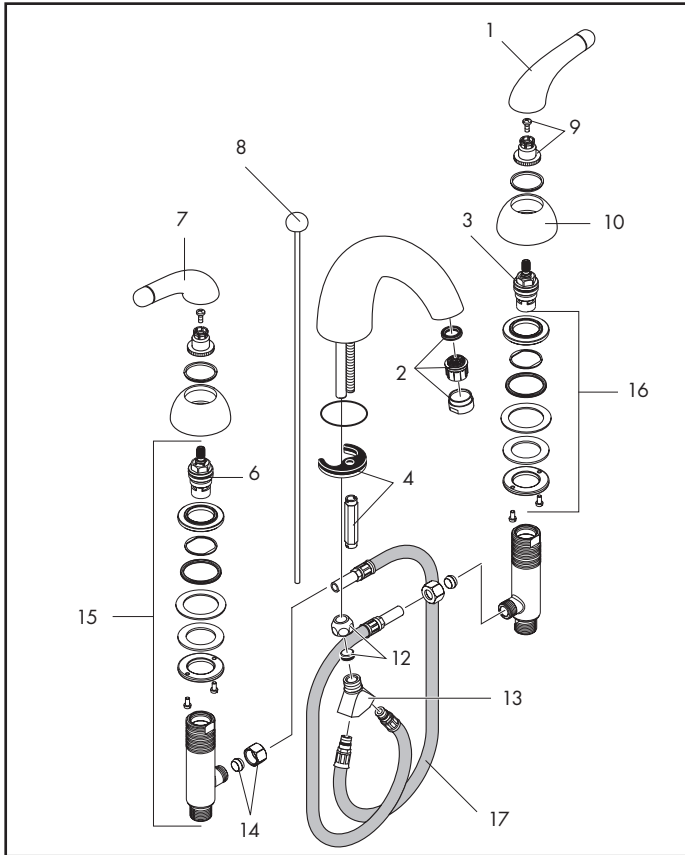

07/99 - 05/02

36135xx1

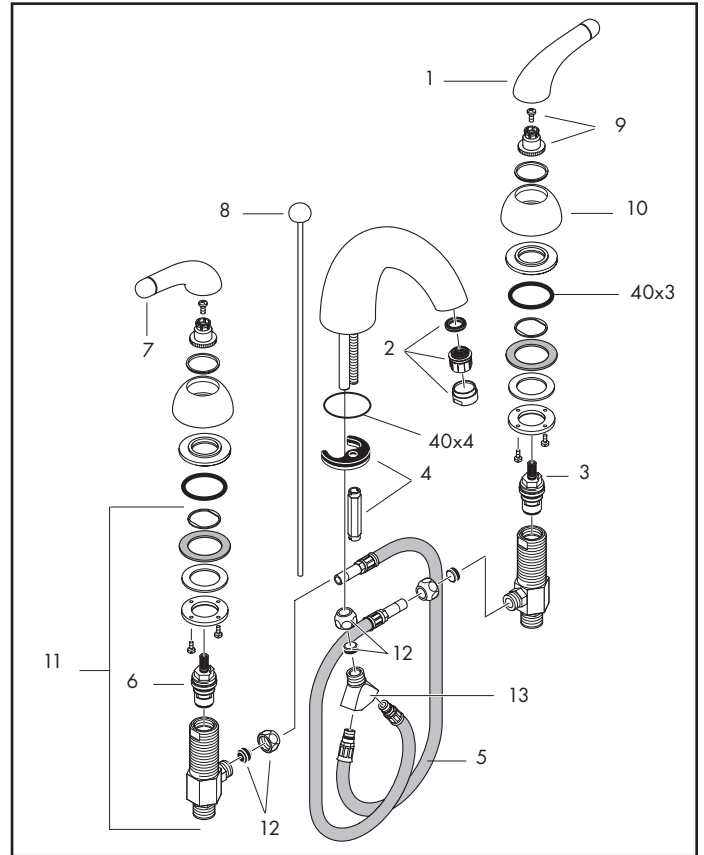

Pos.	Description	Description	Denominación	No./Nr./N°	PG
1	cold handle	poignée eau froide	manija agua fría	36192xx0	1 99
2	aerator	aérateur	aireador	13085xx0	1 4*
3	cold cartridge	mécanisme eau froide	montura agua fría	94008000	1 10
4	fixing set	fixation	set de fijación	96016000	1 9
5	connection hose 18" < 6/96	flex. de raccordements 18"	conexión flexible 18"	88596000	1 7
6	cartridge right closing	mécanisme eau chaude	montura agua caliente	94009000	1 10
7	hot handle	poignée eau chaude	manija agua caliente	36191xx0	1 99
8	pull rod	tirette	tirador	92620xx0	1 9*
9	handle fixing set	entraîneur + vis	anclaje para manija	94184000	1 2
10	escutcheon	rosace	florón	96251xx0	1 99
11	stop valve	robinet d'arrêt	válvula completa	92933000	1 16
12	compression fitting	raccord à bague sertie	tuercas grifería	94158000	set 3
13	hose connection angle	coude de raccordement flexible	rácor de conexión flexo	97753000	1 10
14	3/8 compression fittings	raccord à bague sertie 3/8	tuercas grifería 3/8	88513000	set 4
15	valve set	robinet d'arrêt	válvula completa	88503000	set 17
16	fixing set	fixation	set de fijación	88511000	1 7
17	connection hose	flex de raccordements	conexión flexible	94071001	1 9
	pop-up drain, see p. 4.171	vidage lavabo voir p. 4.171	vaciadores ver p. 4.171	94159xx0	1 14*